

Self-Determined Motivation for Language Learning: The Role of Need for Cognition and Language Learning Strategies [1]

Cameron N. McIntosh [2] and Kimberly A. Noels

1.0 Introduction

Over the last decade, there has been a notable revival of scholarly interest in second language (L2) motivation (see Dörnyei 1998; Oxford 1996a). Since a number of critical reviews of the conceptual and empirical status of L2 motivation theory appeared in the early to mid-1990s (e.g., Crookes and Schmidt 1991; Dörnyei 1994; Oxford and Shearin 1994), several L2 theorists and researchers have made considerable advances in expanding on and complementing existing models of L2 acquisition (SLA; e.g., Clément 1980, 1986; Gardner 1985, 1988; Giles and Byrne 1982; Schumann 1978) by drawing on a variety of non-L2 motivational concepts from both educational and general psychology (see, e.g., Dickinson 1995; Dörnyei 1998; Noels 2001a, 2001b; Noels et al. 1999, 2000, 2001; Oxford 1996a; Tremblay and Gardner 1995; Williams 1994). The present study builds further on this body of work by examining the relations between a number of personality and motivational variables, namely, need for cognition (NC; Caccioppo and Petty 1982), self-determination (Deci and Ryan 1985), and language learning strategies (LLS; Oxford 1990), as well as these variables' relations to L2 achievement.

2.0 L2 Motivation: The Socio-Educational Model

A key framework that has driven much of the research on L2 motivation is Gardner's (1985, 1988; see also Gardner and MacIntyre 1993) Socio-Educational Model of SLA, in which motivation is conceptualized as a complex of variables, specifically, "the combination of effort plus desire to achieve the goal of learning the language plus favourable attitudes toward learning the language" (Gardner 1985: 10). Motivation is hypothesized to have a direct effect on L2 achievement and is itself purportedly influenced by a number of other social-psychological variables. One such variable that has received extensive attention in the L2 literature is the learner's orientation, or reason for learning the L2 (Gardner 1985, 1988; see also Gardner and MacIntyre 1993). Very recently, Noels and her colleagues (Noels 2001a, 2001b; Noels et al. 1999, 2000) have advanced a motivational orientation framework for understanding L2 orientations based on Deci and Ryan's (1985) Self-Determination Theory (SDT).

2.1 Self-Determination Theory

According to Deci and Ryan (1985; see also Deci, Vallerand, Pelletier, and Ryan 1991; Ryan and Deci 2000a; Vallerand 1997), an individual's reason for performing a given activity can be understood in terms of the degree to which it is perceived as freely chosen and endorsed by the self (i.e., self-determined). SDT posits a variety of motivational orientations that can be arranged along a continuum ranging from the most to least self-determined, and maintains that the most positive consequences are associated with the most self-determined orientations (see Deci and Ryan 1985; Deci et al. 1991; Ryan and Deci 2000b; Vallerand 1997). The most self-determined orientation is **intrinsic motivation (IM)**, which refers to a situation in which an activity is performed in order to experience positive affect (i.e., enjoyment and pleasure) inherent in the activity. Vallerand (1997; see also Vallerand et al. 1992, 1993) distinguishes between three highly interrelated types of IM: IM-knowledge (engaging in an activity for the pleasure involved in learning new things), IM-accomplishments (performing a task for the enjoyment inherent in mastering challenges), and IM-stimulation (doing an activity for the general aesthetic pleasure of the experience)

-2-

Next in line on the self-determination continuum is **integrated regulation**, which refers to the state when a person is not motivated to engage in an activity by experiential goals but rather performs the task because it supports a valuable component of his/her identity and self-concept. **Identified regulation** is also a highly self-determined form of motivation and refers to the condition when an individual engages in a task because it will help him/her to achieve an important personal goal. We speak of **introjected regulation** when a person imposes pressure on him/herself to perform an activity. In this case, even though motivation still has an internal source, it is not truly self-determined because the individual feels controlled to a large extent. **External regulation** involves complete external control over the activity by the expectation of rewards or punishments. Finally, **amotivation (AM)** refers to an absence of motivation, that is, there is no regulatory mechanism for the behavior that the individual can identify; AM is essentially akin to the condition of learned helplessness (cf. Abramson, Seligman, and Teasdale 1978). Examples of the different motivational orientations (geared specifically toward the language learning context; cf. Noels et al. 1999, 2000) are displayed in Table 1.

Table 1: Self-Determination Theory: Examples of L2 Motivational Orientations

"Why are you learning a second language?"	
Motivational Orientation	Example
Intrinsic Motivation	
IM-Knowledge	"For the satisfied feeling I get in finding out new things."
IM-Accomplishments	"For the enjoyment I experience when I grasp a difficult construct in the second language."
IM-Stimulation	"For the "high" that I experience while speaking the second language."
Integrated Regulation	"Because it is a part of my identity"
Identified Regulation	"Because I think it is important for my personal development."
Introjected Regulation	"Because I would feel guilty if I didn't know a second language."
External Regulation	"In order to get a more prestigious job later on."
Amotivation	"I don't know, I don't understand what I am doing studying a second language."

Note: Examples are based on scale items designed by Noels and her associates (e.g., Noels et al., 1999, 2000).

-3-

Recent studies by Noels and her associates (see Noels 2001a; Noels et al. 1999, 2000) have extended the tenets of SDT to the study of language learning motivation. Consistent with the notion that a continuum of self-determination underlies the various motivational orientations (Deci and Ryan 1985; Ryan and Deci 2000b), the correlations among L2 orientations based on SDT tend to form a simplex pattern (Noels et al. 2000; see also Vallerand et al. 1992, 1993), that is, orientations having similar levels of self-determination (e.g., IM and identified regulation) correlate more highly than orientations having more disparate levels of self-determination (e.g., IM and external regulation). Furthermore, AM tends to be negatively related to other motivational orientations, particularly IM. Additional research suggests that these orientations have differential predictive power regarding other L2 variables, also suggestive of a self-determination continuum (Noels 2001a; Noels et al. 1999). Specifically, the more self-determined orientations (IM and identified regulation) fairly consistently and positively predict criterion variables such as attitudes toward learning the L2, self-reported effort (i.e., motivational intensity), intentions to continue language study in the future, and self-rated L2 competence. On the other hand, the less self-determined orientations (external and introjected regulation) tend to be more weakly associated with these variables, and AM tends to be negatively associated with them. Overall, it seems that SDT has much potential for broadening understanding of L2 motivational processes.

2.2 Antecedents to Self-Determination

Given the beneficial consequences of self-determined L2 motivation, its potential sources have received considerable research attention (e.g., Noels 2001b; Noels et al. 1999). These studies have been guided by the tenets of SDT suggesting that the social context in which an activity takes place is the key determinant of motivation (Deci and Ryan 1985, 1994; Vallerand 1997). More specifically, the L2 instructor has been considered as an important social agent who can facilitate or hinder self-determination. For instance, Noels et al. (1999) found that perceptions of the L2 instructor and the learning environment in general as "controlling" were negatively related to both IM and identified regulation but positively related to AM. Further, a path-analytic study by Noels (2001a) showed, among other things, that perceptions of the L2 instructor's communicative style as "autonomy-supportive" positively predicted feelings of autonomy in L2 learning, which in turn was positively related to IM and identified regulation and negatively related to AM. While these studies have demonstrated the importance of socio-contextual variables for the development of self-determined L2 motivation, one limitation of the research is that the potential relations between individual difference variables and self-determination have not yet been considered. Indeed, a voluminous body of literature shows that personality variables are important correlates of academic motivation and achievement in general (for reviews, see Furnham 1995; Revelle 1993; see also Busato, Prins, Elshout, and Hamaker 2000) and L2 motivation and achievement in particular (for reviews, see Ellis 1994; Gardner 1985, 1990; Skehan 1989). Thus it seems possible that a better understanding of how the SDT framework figures into SLA could be obtained by integrating it with personality approaches.

-4-

While personality variables have long been considered to be important in SLA and have been examined in

numerous studies, reviewers have noted that this research has yielded inconsistent findings (Ellis 1994; Gardner 1985; Skehan 1989) and has largely been conducted in the absence of well-articulated theoretical premises (Ellis 1994; Gardner 1985). For example, Ellis (1994, Table 11.8, p. 518) summarizes a number of studies investigating the relations of several personality variables (introversion/extroversion, risk-taking, tolerance of ambiguity, empathy, self-esteem, and inhibition) to L2 achievement. With regard to the large degree of unreliability in the results, he states that the "main problem is that there is often no theoretical basis for predicting which personality variables will be positively or negatively related to which aspects of L2 proficiency" (519). Similarly, Gardner (1985), in his review of the literature on personality and L2 learning, comments that to a large degree, the research "seems to be based primarily on vague hypotheses without a clear analytic framework" (16).

It must be noted, however, that some L2 researchers have examined the role of personality in L2 learning more systematically by utilizing well-established, comprehensive models of personality. For example, a major program of research by Ehrman and her associates (e.g., Ehrman 1990a, 1990b, 1994; Ehrman and Oxford 1989, 1995; Oxford and Ehrman 1995) has drawn on the Jungian system of psychological type (see Myers 1987), focusing on the relations among psychological type, preferences in the use of various language learning strategies (LLS), and L2 achievement. While this research is too extensive to review in detail here, one general conclusion that arises from the findings is that these relations appear somewhat ambiguous and unreliable (i.e., inconsistent throughout the various studies). For example, a more recent study (Carrell, Prince, and Astika 1996) found very few significant relations between personality type and L2 achievement. Also, Ellis (1994) notes that many of the findings concerning the connection between preferences for different LLS and personality type are "puzzling" and "counter-intuitive" (542) and maintains that "[i]f there are important links between personality and strategy choice, they remain to be demonstrated" (543).

Another global personality paradigm that has recently been considered within the language learning area is the Big Five Factor Model (FFM; see Costa and McCrae 1996). MacIntyre and Charos (1996) found significant relations between the dimensions of the FFM and a number of L2-related affective variables. For example, they found that openness to experience was positively related to perceived L2 competence, emotional stability was positively related to integrativeness, extroversion negatively predicted L2 anxiety and conscientiousness was positively associated with attitudes toward the learning situation. Thus personality traits would seem to have the potential to enhance understanding of SLA, and there exists a need for further systematic research on this topic.

2.3 Need for Cognition (NC)

The present study focuses on one individual difference variable, NC. As conceptualized by Cacioppo and Petty (1982), NC refers to "the tendency for an individual to engage in and enjoy thinking" (116). Numerous studies support the notion that high-NC persons partake of effortful cognitive activities because they regard thinking as fun in and of itself (for a comprehensive review, see Cacioppo, Petty, Feinstein, and Jarvis 1996). For example, NC has been found to be positively associated with academic curiosity (i.e., a desire to learn about novel subject matter; Olson, Camp, and Fuller 1984), "intellectually-oriented" college goals (such as acquiring a "general education"; Stark, Bentley, Lowther, and Shaw 1991), and a preference for new, thought-stimulating experiences in general (Venkatraman, Marlino, Kardes, and Sklar 1990; Venkatraman and Price 1990). Furthermore, studies have shown that with regard to academic endeavors, high-relative to low-NC university students show both greater persistence (Talbot 1990) and performance (Sadowski and Gulgoz 1992, 1996; Wang and Newlin 2000), with the latter difference being most pronounced when the amount of effortful thought deemed necessary to master the material is high (Leone and Dalton 1988).

-5-

Due to their predisposition to participate in learning activities for the intrinsic enjoyment inherent in thinking, high-NC persons could be seen, in terms of SDT (Deci and Ryan 1985), as chronically more self-determined in their academic endeavors than their low-NC counterparts. Indeed, learning a new language is a cognitively-involving endeavour (Oxford 1990) and would therefore probably be attractive to high-NC persons because it would give them an opportunity to exercise their mental faculties. To be more specific, IM to gain knowledge and to master challenges (Vallerand 1997; Vallerand et al. 1992, 1993) would likely be important reasons for high NC-persons to want to learn an L2. Overall it would be expected that high-relative to low-NC persons should exhibit more self-determined motivational profiles (Vallerand 1997) with regard to L2 learning. The first objective of the present study is to empirically test this assumption.

2.4 Language Learning Strategies (LLS)

A second issue addressed by the present study is the association between self-determination and language learning strategies (LLS), which refer to a wide variety of effortful behaviors and techniques used by students to facilitate their learning of language material (for reviews of theory and research, see Cohen 1990; O'Malley

and Chamot 1990; Oxford 1990, 1993; Oxford and Cohen 1992; Oxford and Crookall 1989). While Noels et al. (1999; see also Noels 2001a, 2001b) found the more self-determined motivational orientations (i.e., IM and identified regulation) to be positively related to self-reported L2 effort (i.e., motivational intensity; Gardner 1985), it is difficult to tell what particular behaviors effort may have comprised. Specifically, these studies used Gardner's (1985) motivational intensity scale, which provides a global, undifferentiated measure of L2 effort. By redefining the concept of effort as the extent to which various specific LLS are employed, however, a more detailed understanding of the role of self-determination in L2 learning might be obtained.

One of the most comprehensive taxonomies of LLS is that of Oxford (1990), who proposed that LLS can be subsumed under two major categories: (1) direct and (2) indirect strategies. According to Oxford (1990), direct strategies "directly involve the target language" in the sense that they "require mental processing of the language" (37). Direct strategies include **memory** (e.g., grouping words on the basis of common attributes, associating words with sounds and imagery), **cognitive** (e.g., reasoning deductively about how to express novel concepts in the L2), and **compensation** strategies (e.g., supplementing words with gestures, guessing at meaning). On the other hand, indirect strategies "provide indirect support for language learning through focusing, planning, evaluating, seeking opportunities, controlling anxiety, increasing cooperation and empathy and other means" (151). Indirect strategies include **metacognitive** (e.g., goal-setting, seeking out practice opportunities, self-evaluation), **affective** (e.g., disclosing feelings about language learning, relaxation techniques), and **social** strategies (e.g., practicing the L2 with fellow learners and fluent L2 speakers; see also Gaies 1985). Much empirical evidence supports the utility of the above framework for categorizing LLS (e.g., Oxford 1996b; Oxford and Burry-Stock 1995).

While a number of studies have demonstrated a positive association between the use of LLS and L2 achievement (e.g., Fleming and Walls 1998; Green and Oxford 1995; Oxford, Park-Oh, Ito, and Sumrall 1993; Park 1997), it has been noted that LLS tend to be underutilized by L2 learners (Cohen 1990; Oxford and Crookall 1989). Thus the predictors of LLS usage are obviously of considerable interest to L2 theorists, researchers, and instructors. Another objective of the present study is to determine the link between self-determined L2 motivation and the use of LLS. Indeed, although perhaps confounded to a certain extent by differing conceptual and operational definitions of L2 motivation, several studies suggest that L2 motivation is a reliable correlate of LLS (see, e.g., Gardner, Tremblay, and Masgoret 1997; MacIntyre and Noels 1996; Oxford 1990; Oxford and Ehrman 1995; Oxford and Nyikos 1989). Determining the relations between self-determination and LLS could potentially enhance understanding of the antecedents of strategy use, as well as of the processes by which self-determination might be associated with L2 achievement.

-6-

Finally, considering the nature of some of the LLS, it seems tenable to posit direct links between NC and strategy use, in addition to an indirect connection via self-determination. Specifically, given high-NC persons' proclivity for enjoyment of effortful thought, we propose that they will be more likely to engage in the more thought-intensive LLS, namely memory and cognitive strategies, than their low-NC counterparts. Since memory strategies consist of fairly mentally-involving techniques such as "semantic mapping" (Oxford 1990: 41), that is, placing a word within a mental network of related words and concepts, high-NC persons should be more inclined to use them. Also, high-NC persons should be more likely than low-NC individuals to make use of cognitive strategies, as cognitive strategies entail "'deep processing', which involves making the material one's own through analysis, synthesis, and the continuous development and adjustment of schemata (Schmeck, Geisler-Brenstein, and Cercy 1991)" (Ehrman and Oxford 1995: 78).

3.0 The Present Study: Hypotheses

On the basis of the preceding literature review and discussion, a theoretical process model was formulated (see Figure 1). Each numbered pathway shown in Figure 1 corresponds to a particular hypothesis. Specifically, Hypothesis 1 holds that NC will be positively associated with self-determination in L2 learning. Hypotheses 2 through 7 state that self-determination in L2 learning will be positively related to all six types of LLS. Hypotheses 8 and 9 state that NC will be positively related to the use of memory and cognitive strategies, respectively. Hypotheses 10 through 15 hold that all six LLS will positively contribute to L2 proficiency.

Figure 1. Theoretical Process Model for Study Variables

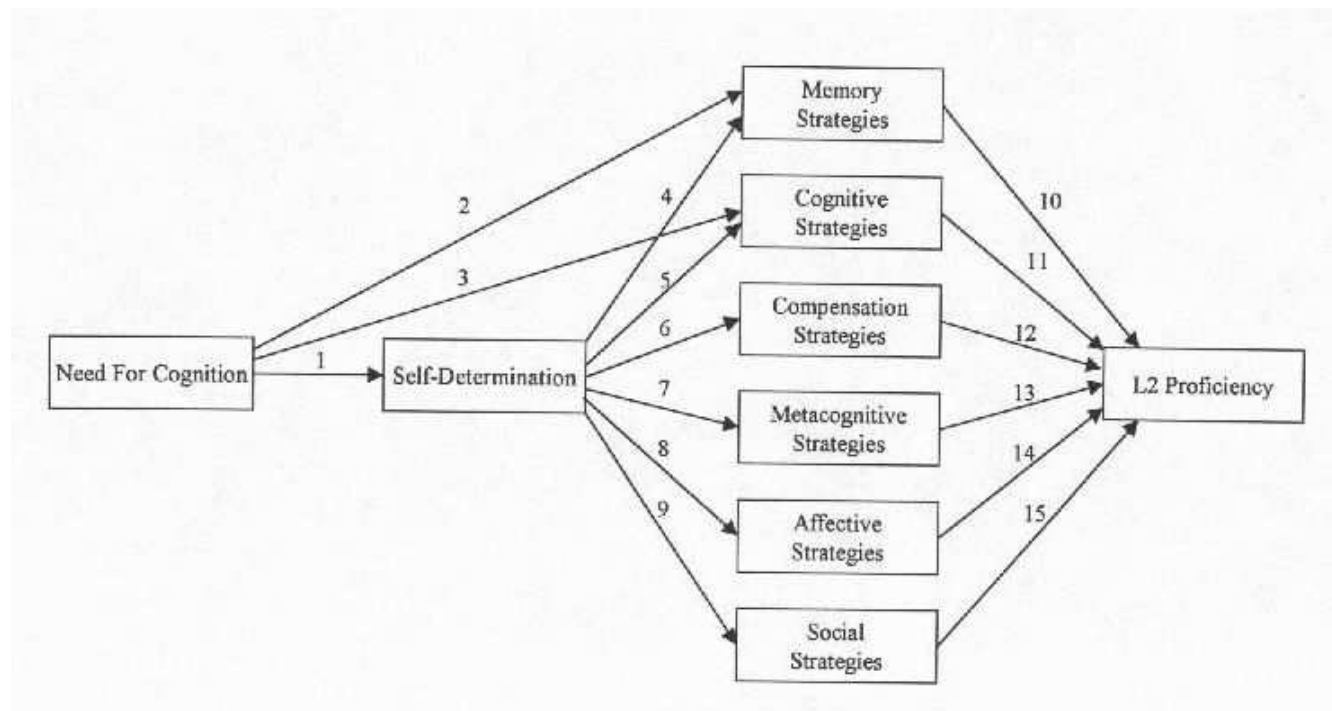

Note: Numbers correspond to hypotheses described in the text.

-7-

3.1 Method

Participants

The sample consisted of 126 undergraduate student volunteers (74% female) enrolled in language courses at the University of Saskatchewan. Ages ranged from 17 to 50 years ($M = 21.47$, $SD = 5.71$). With regard to university levels, 41% of the sample were in their first year, 26.2% were in their second year, 18.9% were in their third year, 9.8% were in their fourth year, and 4.1% were in their fifth year. Regarding the language courses in which the participants were enrolled, 55.2% of the sample indicated that they were French learners, 37.6% were Spanish learners, and 7.2% were learning German. Regarding the level of the courses students were taking, 40.7% of the sample indicated that they were enrolled in an elementary course, 43.9% were taking an intermediate course, and 15.4% were taking an advanced course. English was the mother tongue for 76.6% of the participants, 6.5% were Francophone, and 1.6% indicated that German was their mother tongue. A preponderance of the sample (88%) indicated that they spoke English most frequently. The participants began learning the language taught in their course between zero and 50 years ($M = 13.56$; $SD = 9.31$), and indicated that they had been learning the language from less than one year to 31 years ($M = 7.10$; $SD = 6.81$).

Materials (see Appendix)

Need for cognition (NC). Participants completed the short (18-item) form of the NC scale (Cacioppo, Petty, and Kao 1984), designed to measure stable individual differences in people's inclination to partake of effortful cognitive activity (e.g., "I prefer complex to simple problems"). Participants responded to the items on a 7-point Likert-type scale ranging from 1 (strongly agree) to 7 (strongly disagree). The scoring on the positively phrased items was reversed prior to the analysis so that higher scores indicated a higher NC ($\alpha = .81$).

Self-determination continuum. Participants completed a 32-item scale consisting partly of items developed by Noels et al. (2000; see also Noels et al. 1999) to measure orientations toward language learning in accordance with Deci and Ryan's (1985) self-determination theory. Based on discussions with language instructors, additional items were included (Senior, personal communication, December, 1999). Four items assessed IM-knowledge ($\alpha = .78$), IM-accomplishment ($\alpha = .85$), IM-stimulation ($\alpha = .82$), integrated regulation ($\alpha = .84$), identified regulation ($\alpha = .77$), introjected regulation ($\alpha = .68$), external regulation ($\alpha = .72$), and AM ($\alpha = .87$; refer to Table 1 for examples of each type of motivational orientation). Participants were asked to respond to the items in light of the language of the course in which they were enrolled, using a 7-point Likert-type scale ranging from 1 (strongly agree) to 7 (strongly disagree). All items were reverse-coded so that higher scores on all items meant stronger endorsement of the reason presented for learning the L2.

Language learning strategies (LLS). In order to facilitate ease of completion of the survey instrument, participants were administered the 50-item version of the SILL (Oxford 1990) designed for use with ESL/EFL students rather than the 80-item version designed for native English speakers. Although the 50-item version is much simpler in format than the 80-item version, Oxford (1990: 199) notes that both forms function similarly. Indeed, the 50-item version has been demonstrated to have sound psychometric properties (Oxford 1996b; Oxford and Burry-Stock 1995) and has shown meaningful associations with indexes of other language learning-related variables in non-ESL/EFL contexts (e.g., MacIntyre and Noels 1996). The strategies assessed by the SILL are memory (e.g., "I use rhymes to remember new words in the second language"; $\alpha = .72$), cognitive (e.g., "I try to find patterns in the second language" $\alpha = .76$), compensation (e.g., "I make up new words if I do not know the right ones in the second language"; $\alpha = .82$), metacognitive (e.g., "I notice my second language mistakes and use that information to help me do better"; $\alpha = .86$), affective (e.g., "I try to relax whenever I feel afraid of using French"; $\alpha = .55$), and social strategies (e.g., "I practice the second language with other students"; $\alpha = .82$). The overall alpha for the SILL was .92. Items were adapted to the language that each class was studying. Participants responded to the items on a scale ranging from 1 (never use it) to 7 (always use it). Higher scores indicated higher frequency of strategy use.

L2 achievement. In order to obtain a measure of L2 achievement, participants were requested to release their final course grades to the researchers. (Sixty-five students authorized the release of this information.) Additionally, participants completed a 4-item measure of self-perceptions of L2 proficiency (cf. Clément 1988). Specifically, participants were asked to rate how well they thought they wrote, understood, read, and spoke the language they were currently learning on a scale ranging from 1 (not at all) to 7 (very well). Higher scores indicate higher perceived L2 competence ($\alpha = .86$). While it would have been preferable from a research perspective to have more than the above two indicators of L2 competence, such as other writing, comprehension, and oral diagnostics, both the authors and professors were attempting to minimize interference in the students' language studies (e.g., the students completed the questionnaire outside of class). Thus the use of the final course grade as well as the self-rating scale seemed to provide a reasonable compromise.

Procedure

At the beginning of their lectures, students were asked if they would be willing to participate in a study "investigating how psychological differences among language learners, such as attitudes and personality traits, affect both the process and outcome of language learning." The researchers emphasized the voluntary and confidential nature of the study, assuring them that their instructors would not have access to their responses. Participants completed the questionnaires on their own time and returned them in sealed envelopes to their instructors (a one-week period was designated), who then forwarded the sealed envelopes to the researchers. Participants were also asked if they would be willing to release their final course grades to the researchers for the purposes of the study.

3.2 Results

Two separate sets of analyses were conducted in order to address the present hypotheses. In the first analysis, structural equation modeling (SEM; see Hoyle 1995; Marcoulides and Schumacker 1996) was used for a simultaneous test of the components of the proposed model (Figure 1). Given that only 65 of the participants authorized the release of their course grades for research purposes, however, only self-ratings of proficiency were used in the SEM analysis. To include participants who supplied their final course grades would reduce the sample size to the extent that SEM results might not be trustworthy. (e.g., Boomsma [1982] recommends 100 as the minimum acceptable sample size). Therefore, the decision was to examine the relations between final course grades and the other study variables in a hierarchical multiple regression analysis. The results of these two sets of analyses are presented below, in turn. It should be noted here that for all of the present inferential tests, a significance level of .05 was selected for marking the boundary between random sampling fluctuations and substantively meaningful results. While the authors are aware of critical debates surrounding conventional p -values and the use of significance testing in general (e.g., Cohen 1994), .05 is the most widely-used and accepted value among social science researchers. Therefore, it was chosen here in order to maintain consistency with the majority of the literature.

3.2.1 A Test of the Process Model: Structural Equation Modeling (SEM)

Prior to model testing, missing data (less than 5% of the total data points) were replaced with the series mean, that is, the mean score for the valid cases on a variable (Tabachnick and Fidell 1996). Next, a number of indexes were constructed in order to test the model. First, the latent factor of NC was defined by two

indicators, each of which is an aggregate or "parcel" of nine NC items. When the number of measured variables is large, using homogeneous item clusters as indicators for latent variables is a typical procedure in SEM (see Hoffman 1995; Yuan, Bentler, and Kano 1997). All six LLS were incorporated into the model as measured variables, each consisting of mean subscale scores. Given that the LLS have typically been found to be interrelated (e.g., Gardner et al. 1997; Oxford 1990, 1996b; Oxford and Burry-Stock 1995), their errors of prediction were left free to correlate (Bentler 1998; Byrne 1994). The latent factor of perceived L2 competence was defined by four indicators (reading, writing, speaking, and understanding).

Further, to assess self-determined L2 motivation, the various motivational subscales were combined into composite self-determination indexes (see Fortier, Vallerand, and Guay 1995; Guay and Vallerand 1997; Vallerand 1997; Vallerand, Fortier, and Guay 1997). This procedure involves weighting the items and then summing the products, with the weights being ascribed on the basis that the motivational subtypes are assumed to lie on a self-determination continuum ranging from intrinsic motivation to amotivation (Deci and Ryan 1985). The weights are assigned as follows (cf. Vallerand 1997: 286): IM (+3), integrated regulation (+2), identified regulation (+1), introjected regulation (-1), external regulation (-2), and AM (-3). All three types of intrinsic motivation are weighted identically, and then the sum of the products is divided by three so that it is comparable to that of the other motivational orientation scales (Vallerand, 1997. p. 286). Four SDIs (each using one item from each subscale) were calculated using the following formula: $(3X(\text{IM-knowledge}) + 3X(\text{IM-accomplishment}) + 3X(\text{IM-stimulation})/3 + 2X(\text{integrated regulation}) + 1X(\text{identified regulation}) - 3X(\text{AM}) - 2X(\text{external regulation}) - 1X(\text{introjected regulation}))$. Thus a positive score represents a relatively self-determined motivational profile while a negative score represents a relatively non-self-determined motivational profile (Vallerand 1997: 286). The number of indexes was further reduced to two by averaging, and the two indexes functioned as indicators of a latent self-determination factor.

-10-

The correlation matrix, means, and standard deviations for the study variables are presented in Table 2. It is important to point out here that a number of the correlations, while statistically significant, were small in terms of absolute size. For example, perhaps a bit contrary to the relevant literature as well as intuition, the correlations between the two NC indexes and cognitive LLS were only .26 and .28. Further, some of the significant relations among the SD indexes and LLS were rather low, ranging from .21 (affective) to .41 (metacognitive). However, these results would seem to reflect the complexity of motivational processes in language learning in general (see Dörnyei 1994, 1998); and specifically that numerous factors are associated with the use of LLS (e.g., Ehrman and Oxford 1989, MacIntyre and Noels 1996; Oxford 1993).

Table 2: Correlation Matrix, Means, and Standard Deviations for Study Variables

Variable	<u>M</u>	<u>SD</u>	1	2	3	4	5	6	7	8	9	10	11	12	13	14	15
NC1-1	5.12	.73	----														
NC2-2	5.32	.60	.51**	----													
SD1-3	14.24	8.28	.35**	.39**	----												
SD2-4	13.52	8.51	.33**	.37**	.71**	----											
MEM-5	3.42	.96	-.00	.07	.13	.08	----										
COG-6	3.82	.86	.28**	.26**	.38**	.33**	.37**	----									
COMP-7	4.12	1.11	.23*	.19*	.23*	.24**	.32**	.56**	----								
META-8	3.93	1.12	.20*	.18*	.41**	.38**	.31**	.77**	.46**	----							
AFF-9	3.01	.93	.01	.01	.21*	.07	.39**	.36**	.33**	.40**	----						
SOC-10	3.99	1.30	.10	.18*	.32**	.31**	.25**	.64**	.41**	.62**	.17	----					
SRP1-11	4.50	1.09	.21	.14	.16	.25**	.08	.20*	.06	.16	.05	.16	----				
SRP2-12	5.03	1.25	.15	.04	.10	.28**	-.08	.19*	.13	.17	.02	.29**	.63**	----			
SRP3-13	4.90	1.20	.25**	.19*	.19*	.26**	.01	.27**	.20*	.25**	.01	.26**	.58**	.68**	----		
SRP4-14	4.18	1.31	.02	-.02	.03	.24**	-.06	.12	.07	.20*	.05	.22*	.49**	.75**	.54**	----	
FCG-15 ^a	75.92	12.19	.05	.25	.09	-.06	.06	.22	.20	-.08	.17	.08	.02	.14	.22	.06	----

Note: $N = 126$. NC = Need for Cognition; SD = Self-Determination; MEM = Memory Strategies; COG = Cognitive Strategies; COM = Compensation Strategies; META = Metacognitive Strategies; AFF = Affective Strategies; SOC = Social Strategies; SRP = Self-Ratings of L2 Proficiency; FCG = Final Course Grade.

^a $n = 65$

** Coefficient is significant at the .01 level (two-tailed).

* Coefficient is significant at the .05 level (two-tailed).

-11-

A structural analysis of the covariance matrix for the study variables was conducted using the EQS program (version 5.7b; Bentler 1998). Parameters were estimated using the Maximum-Likelihood (ML) technique, and the following global fit indexes were used to determine the discrepancy between the empirical and model-implied covariance matrices: chi-square (χ^2), Bentler's (1990) normed Comparative Fit Index (CFI), and Steiger's (1990) Root Mean Squared Error of Approximation (RMSEA). Traditionally, the cutoff value used for the CFI has been .90 (Bentler 1990, 1998), and the following guidelines suggested by Browne and Cudeck (1993; see also Steiger 1990) have generally been used for the RMSEA: (1) a value of .05 or less is indicative of very good model fit, (2) a value of .08 shows acceptable fit, and (3) a value greater than .10 shows that the model is untenable. Hu and Bentler's (1999) recent Monte Carlo work, however, has shown that conventional criteria for evaluating global model fit appear to be somewhat inadequate; specifically, extant cutoff values for a number of fit indexes still permit the acceptance of too many severely misspecified models. Thus they have suggested new, more stringent cutoff values for a number of global fit indexes. For the CFI and the RMSEA, respectively, Hu and Bentler (1999) recommend that values close to .95 and .06 should be obtained before a model can be judged an adequate explanation of sample data. These new fit criteria are employed in the present study.

The global fit indexes showed that the model reproduced the sample data very well, χ^2 (53, $N = 126$) = 68.43, $p = .08$; CFI = .98; RMSEA = .05. Inspection of the individual parameter estimates, however, revealed that a number of them were nonsignificant (i.e., had z -values < 2.00); specifically, the relations between NC and memory strategies, self-determination and both memory and affective strategies, social and affective strategies, and perceived L2 competence and all but social strategies. The nonsignificant components of the model were accordingly deleted and the model re-estimated. The fit indexes still showed a good match between the model and the data (χ^2 (62), $N = 126$) = 77.65, $p = .09$; CFI = .98; RMSEA = .05. Further, all parameter estimates were significant (z -values > 2.00). Because of the modifications made to the model, a bivariate correlation was computed between the parameter estimates (regression coefficients and variances and covariances of the independent variables; Bentler 1998) present in both models (cf. Ullman 1996: 785). Results showed that the modifications did not alter the other parameter estimates ($r(45) = .998$, $p < .001$), however, and all coefficients were still in the predicted direction. The final model with coefficients in standardized form is presented in Figure 2.

Figure 2. Final Model

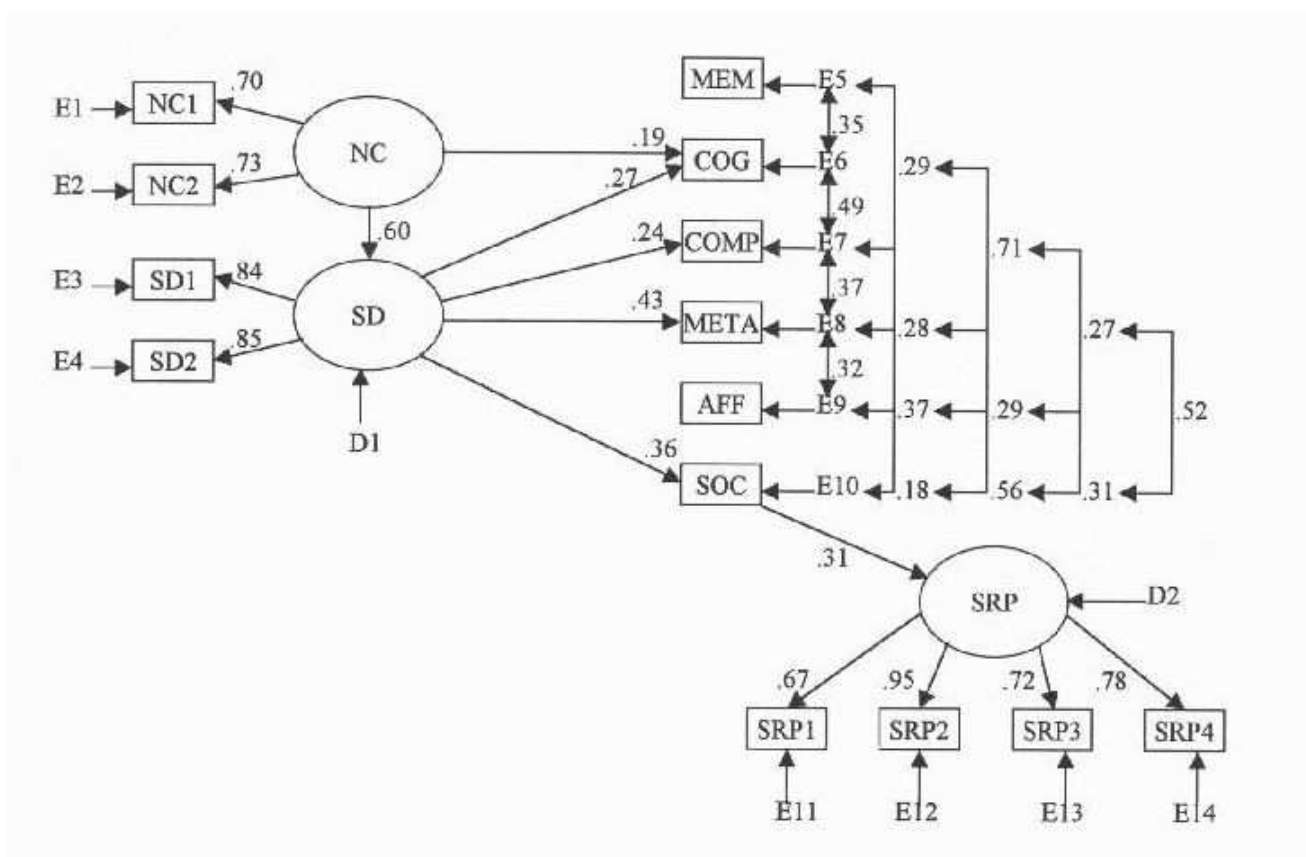

Note: NC = Need for Cognition; MEM = Memory Strategies; COG = Cognitive Strategies; COMP = Compensation Strategies; META = Metacognitive Strategies; AFF = Affective Strategies; SOC = Social Strategies; SD = Self-Determination; SRP = Self-Ratings of L2 Proficiency.

-12-

3.2.2 Relations Among Course Grades and Study Variables: Hierarchical Regression Analysis

As noted previously, course grades were not incorporated into the SEM analysis due to concerns about adequate sample size. Therefore, the alternative strategy for examining the relationships among course grades and the study variables was to conduct a hierarchical regression analysis with the subsample that had complete scores on all the relevant indices. Specifically, the independent variables were entered into the regression equation in blocks to predict grades; specifically, NC ($M = 5.28$, $SD = .57$) was entered on the first step, self-determination (the average of the two indexes used in the SEM; $M = 15.70$, $SD = 7.26$) was included on the second step, and all six LLS from the SILL were included on the final step (see Table 3).

Table 3: Results of Hierarchical Regression Analysis Examining the Influence of Need for Cognition, Self-Determination, and Language Learning Strategies on Final Course Grade

Variables	Equation						Coefficients		
	R^2	F	SigF	ΔR^2	ΔF	Sig ΔF	r	β	t
FINAL COURSE GRADE									
<u>Block 1</u>	.03	1.72	.20	--	--	--			
NC							.16	.16	.131
<u>Block 2</u>	.03	1.03	.36	.01	.36	.55			
NC							.16	.21	1.43
SD							.01	-.09	-.602
<u>Block 3</u>	.22	1.96	.07	.19	2.23	.05			
NC							.16	.06	.433
SD							.01	-.03	-.198
MEM							.06	-.00	-.01
COG							.22	.52*	2.47*
COMP							.20	.14	.942
META							-.08	-.35	-1.90
AFF							-.17	-.24	-1.54
SOC							.08	-.04	-.258

Note: $n = 65$. NC = Need for Cognition; SD = Self-Determination; MEM = Memory Strategies; COG = Cognitive Strategies; META = Metacognitive Strategies; AFF = Affective Strategies; SOC = Social Strategies.

* significant at the .01 level.

As shown in Table 3, only the final block contributed to the prediction of final course grade; specifically, only cognitive strategies showed a significant relation with final course grade. What is interesting, however, is that while the zero-order correlation between cognitive strategies and achievement is not reliably different from zero, $r(64) = .22$, $p = .08$, the beta weight for cognitive strategies is significant, $\beta = .52$, $t = 2.47$, $p < .05$. In multiple regression analysis, the situation in which the beta weight for a predictor is larger than the zero-order correlation between the predictor and criterion is known as suppression (cf. Cohen and Cohen 1983: 94-96; Pedhazur 1997: 186-188; Tabachnick and Fidell 1996: 165). In this case, the "true" relations between two predictors and a criterion are being masked by the correlation between the predictors, in the sense that the correlation between the predictors adds variance to the analysis that is irrelevant to the prediction of the criterion. In other words, the predictors have something in common that they do not share with the criterion and this irrelevant variance obscures or hides their actual relations with the criterion. When the predictors are entered into the analysis together, however, they are made statistically independent of each other; therefore, irrelevant variance or "noise" is removed or "suppressed" and the relations between the predictors and the criterion improve as a result.

-13-

Once it is apparent that a suppression effect is present, the next step is the identification of the specific suppressor variable(s) (Tabachnick and Fidell 1996). In the present analysis, it is not immediately clear which of the other predictor(s), when removed from cognitive strategies, functions as a suppressor variable and thereby helps to purify the relation between cognitive strategies and achievement. Identification of suppressor variables can often be difficult, especially when there are a large number of predictors in the equation (Tabachnick and Fidell 1996), as in the present study. Unfortunately, no clear, general criteria have been developed for the analysis of suppressor effects. One suggestion (Tabachnick and Fidell 1996) has been to remove predictors individually from the equation and watch for any reductions in the beta weight for the predictor(s) on which the suppression effects appear to be operating (in this case, cognitive strategies). The hierarchical regression analyses conducted above was repeated seven times. Each time, a different predictor was removed from the analysis and the beta weight for cognitive strategies was observed for downward fluctuations. (The deleted predictor was reinserted into the equation for subsequent analyses, so only one variable was missing in each step). In three of the analyses, there were reductions in the beta weight for cognitive strategies, such that when metacognitive, affective, and social strategies were removed from the equation, the β s for cognitive strategies were, respectively, .37 ($t = 1.86, p = .07$), .49 ($t = 2.30, p < .05$), and .50 ($t = 2.55, p < .05$). Metacognitive strategies appear to be operating as powerful suppressors, given that the deletion of this variable from the equation was the only deletion that resulted in a non-significant beta weight for cognitive strategies. Although the association between cognitive strategies and grades diminished somewhat with the removal of social and affective strategies from the equation, these suppression effects do not appear very strong.

We conducted some follow-up analyses to examine in more detail the nature of the suppression effects. The rationale was that if a variable does in fact function as a suppressor regarding the relation between grades and cognitive strategies, a significant coefficient of determination (R^2) should be obtained by using only that variable in combination with cognitive strategies to predict achievement. Thus a series of seven standard (i.e., simultaneous) regression analyses were conducted, each using cognitive strategies and one of the other study variables as predictors of achievement. With the exception of two of the analyses, the variance explained in achievement was nonsignificant. Cognitive and metacognitive strategies accounted for 16% of the variance in grades, $F(2, 62) = 5.68, p < .01$, with the β 's for the two predictors being, respectively, .54 ($t = 3.30, p < .01$) and -.45 ($t = -2.78, p < .01$). Considering cognitive and affective strategies together explained 14% of the variance in achievement, $F(2, 62) = 5.21, p < .01$, with the β 's for the two predictors being, respectively, .39 ($t = 2.90, p < .01$) and -.35 ($t = -2.61, p < .01$). Therefore these results suggest that metacognitive and affective strategies are most appropriately considered suppressor variables with regard to the relation between cognitive strategies and achievement. It is also worth adding that affective and metacognitive strategies did not produce a useful prediction equation, $R^2 = .03, F(2, 62) = 5.68, p = .42$, suggesting that the suppression effects revealed here with regard to using the above three strategies to predict achievement appear to center around cognitive strategies. Also, the above results suggest that cognitive and metacognitive strategies appear to function as mutual suppressors, as do cognitive and affective strategies, given that neither affective nor metacognitive strategies showed significant zero-order correlations with grades.

4.0 Discussion

The purpose of this study was to test a theoretical process model of second language acquisition, in which need for cognition (NC) was hypothesized to influence self-determination to learn an L2, which would in turn lead to the use of a variety of language learning strategies (LLS) and thereby greater L2 proficiency. Both structural equation modeling (SEM) and hierarchical multiple regression were used to test the viability of the model. The results of each of these analyses are discussed below, in turn.

4.1 NC, LLS and the Process Model

The final model showed partial support for the hypothesized relations. First of all, the significant and positive association between NC and self-determination in L2 learning suggests that people who enjoy effortful thinking for its own sake also take an L2 for self-determined reasons (i.e., out of choice and pleasure). This finding is in line with research showing that high-NC individuals tend to engage in educational activities more out of personal interest and enjoyment than their low-NC counterparts do (e.g., Olson et al. 1984; Stark et al. 1991). Therefore these results add to the work of Noels and her colleagues (see Noels 2001b for an overview) on the antecedents of self-determination in L2 learning contexts. While these studies by Noels and her associates have shown that perceptions of the L2 environment (in particular, perceptions of the instructor's communicative style) are important predictors of self-determination, the present findings regarding NC suggest that certain personality traits might also be related to self-determination. Thus it appears that both the L2 learner and the learning environment need to be taken into account when examining self-determination. Further, the present findings suggest potentially profitable avenues for future research on

SDT within academic settings in general. Specifically, the research within the SDT framework on academic motivation has focused on sociocontextual rather than individual difference variables as sources of self-determination (see Deci and Ryan 1994; Vallerand 1997). It should be noted at this point, however, that a number of studies have examined the association between personality variables and intrinsic and extrinsic academic motivation more generally (e.g., Brownlow, Gilbert, and Reasinger 1999; Koestner, Zuckennan, and Olsson 1990; Waschull and Kernis 1996). The present results suggest that Deci and Ryan's (1985) framework in particular could be further enriched by considering how personality variables influence self-determined academic motivation.

In addition to predicting self-determination in L2 learning, NC was found to be directly and positively related to cognitive strategies. This finding is in good agreement with the large body of research showing that high-NC persons have a proclivity for intrinsic enjoyment of effortful information processing in a wide variety of contexts and situations (Cacioppo et al. 1996). Also, these results demonstrate further that personality is an important correlate of strategy choice. Specifically, in addition to the widely studied Jungian model (see Carrell, Prince, and Astika 1996; Ehrman 1990a, 1990b, 1994; Ehrman and Oxford 1989, 1995), it appears that other personality constructs can contribute to our understanding of L2 learners' preferences for certain LLS. There is likely much rich information to be gained from further integration of the personality literature with the work on LLS.

-15-

Contrary to predictions, no relation was found between NC and memory strategies. Given that memory strategies do not involve the same extent of effortful information processing as cognitive strategies do (see Oxford, 1990), however, it is possible that high-NC persons might not be inclined to use them to a greater degree than low-NC individuals. Indeed, research has demonstrated that differences in the extent of mental processing between high- and low-NC persons emerge only when the task is cognitively challenging (e.g., Leone and Dalton 1988; Petty, Cacioppo, and Kasmer 1985, as cited in Cacioppo et al. 1996). Of course, this explanation for the present lack of a relation between NC and memory strategies is somewhat speculative at this point, and therefore requires verification in further empirical research.

The finding that self-determination in L2 learning was positively related to the use of a variety of language learning strategies (cognitive, compensation, metacognitive, and social strategies; Oxford 1990, 1996b) builds on the findings by Noels and her colleagues (Noels 2001a; Noels et al. 1999) that self-determined L2 motivation positively predicts self-reported effort (motivational intensity; Gardner 1985). Specifically, the present study moves beyond the broad self-determination-effort connection by demonstrating that self-determination is associated with a number of specific LLS identified in the L2 literature (Oxford 1990). Thus these results provide further support for the utility of SDT for predicting language learning-related variables.

It should be noted that, inconsistent with the predictions, self-determination was not associated with the use of all six LLS. Specifically, self-determination was not related to memory and affective strategies. While it is difficult to speculate on the lack of support for these hypotheses, these results do indicate further that richer information can be obtained by considering specific L2 learning behaviors rather than general L2 effort as correlates of self-determination. Simply considering general L2 effort may obscure the fact that not all particular forms of L2 effort (i.e., LLS) will always be a function of self-determination. It is clear, however, that more research needs to be conducted to determine the circumstances under which self-determination will and will not predict the use of certain LLS.

Further, the use of social strategies was positively related to self-perceptions of L2 proficiency. As suggested in both the general educational literature on social strategies (e.g., Dansereau 1988; Slavin 1980, 1983) and the L2 literature on this topic (e.g., Gaies 1985; Oxford 1990, pp. 144-146), cooperative learning can work to create mutual support and increased morale, leading to greater feelings of competency in the subject matter as well as higher levels of achievement. It is important to keep in mind, however, that strong causal inferences regarding the relation between perceived competence and social strategies are not warranted here, given the correlational and cross-sectional nature of this design. A plausible alternative explanation for this relationship is that the higher the level of perceived L2 competence, the greater the willingness to engage in cooperative learning. The literature on language anxiety (cf. Horwitz and Young 1991; MacIntyre 1995; MacIntyre and Gardner 1989, 1991) suggests that those who feel less competent in the L2 also experience more anxiety in using it in social settings and tend to avoid such situations. Of course, the relation between social strategies and perceived L2 competence could quite easily be reciprocal, in the sense that, for example, learning with others could help build perceived L2 competence which reduces anxiety about future cooperative learning and increases the tendency to engage in it in the future.

-16-

It is also worth noting that some social psychological perspectives on SLA are relevant to the present findings and discussion concerning the relation between social strategies and achievement. For example, Clément (1980; see also Clément and Kruidenier, 1985) theorized that both the frequency and quality (i.e., pleasantness) of contact with members of the target language group would positively influence self-confidence in using the L2 (i.e., the absence of language anxiety and the presence of perceived L2 competence). Given that these classes of variables likely function in the context of the L2 classroom as well as in the social milieu (cf. Clément, Dörnyei, and Noels 1994), these views would seem to have potential bearing on the present link between social strategies and perceived L2 competence. Specifically, frequent cooperation with other students in order to learn the target language, which Oxford (1990) notes serves to "encourage 'positive interdependence' and mutual support" (145-146), would likely engender perceived competence in using the L2 (see also Gaies 1985). Overall, it is clear that further research on the above issues, employing experimental and longitudinal designs, is needed to clarify the nature of the relation between social strategies and perceived L2 competence.

Another unanticipated finding concerning the LLS was that with the exception of social strategies, none of the LLS predicted self-perceptions of proficiency. These findings are inconsistent with research showing that the use of a wide range of LLS contributes to L2 attainment (e.g., Fleming and Walls 1998; Green and Oxford 1995; Oxford, Park-Oh, Ito, and Sumrall 1993; Park 1997). However, it is important to note that the present study used self-perceptions of L2 competence as an index of achievement, while these other studies used more objective measures of achievement. The present results suggest that even though L2 learners engage in a number of strategies to assist them in their learning, they do not derive their feelings of competency in the L2 from most of them. Perhaps it is not enough that learners simply use the strategies--they probably need to obtain tangible results (i.e., success) from their use in order to feel competent.

4.2 Strategy Use and Course Achievement

An examination of the link between strategy use and more objective assessments of L2 achievement (final course grade), however, also suggested that not all strategies are relevant to L2 proficiency. [3] The hierarchical regression analysis showed only one significant relation, namely that between cognitive strategies and achievement. However, this relation is unusual in the sense that there is no bivariate association between these variables but rather a "hidden" one that is "uncovered" by including both affective and metacognitive strategies (identified here as suppressor variables) in the analysis.

One possible explanation for the finding that cognitive strategies were more strongly positively related to achievement when considered independently of affective strategies comes from the literature on language anxiety (cf. Horwitz and Young 1991; MacIntyre 1995; MacIntyre and Gardner 1989, 1991). First of all, the general view presented in these works is that negative L2-related thoughts and emotions (e.g., worry, tension and discomfort when using the language) use up mental energy that could be utilized to process language material. The rationale for the negative impact of anxiety on task performance is well-articulated by Eysenck (1979, quoted in MacIntyre 1995: 91; see also Sarason 1986; Tobias 1986):

[W]orry and other task-irrelevant cognitive activities associated with anxiety always impair the quality of performance. The major reason for this is that the task-irrelevant information involved in worry and cognitive self-concern competes with task-relevant information for space in the processing system. As a result, highly anxious subjects are effectively in a dual-task or divided situation, in contrast to the non-anxious subjects who primarily process task-relevant information (364).

-17-

Indeed, the present results suggest that preoccupation with managing and controlling L2-related anxiety (i.e., affective strategies) consumes time and mental resources necessary for effective cognitive processing of language material. When the use of cognitive strategies is not being "hampered" by the use of affective strategies, however, it seems that greater L2 achievement is the result. It is worth adding that these results are also in line with certain theoretical perspectives on stress and coping in general (cf. Lazarus and Folkman 1984). Specifically, Lazarus and Folkman (1984) suggest that emotion-focused coping (which would be an appropriate classification for affective strategies) may lead to detrimental outcomes (e.g., decreased L2 achievement), since it involves attempts to minimize the emotional impact of stressors (e.g., insufficient knowledge of the L2) but not deal with the stressors themselves. On the other hand, problem-focused coping (in the present case, using cognitive strategies or actively processing language material) leads to more positive consequences, since it deals directly with the stressors.

Further, the finding that affective strategies were more strongly negatively related to achievement when cognitive strategies are partialled out suggests that increased use of cognitive strategies is helping to "prevent" the use of affective strategies from having a negative influence on achievement. In other words, the use of

reasoning and problem-solving to deal with difficulties involving the language material could "offset" to some degree the negative effects of being preoccupied with simply managing negative affect related to learning problems. Indeed, a number of theorists (e.g., McCroskey and Richmond 1991; Sarason 1986) have suggested that skills training needs to be used in conjunction with anxiety-reduction techniques in order to produce increments in achievement for students experiencing task-related anxiety (see also MacIntyre and Gardner 1994). The present results would seem to support these views, and suggest further that simply trying to overcome L2 difficulties by managing associated negative emotions rather than active mental engagement in learning the material actually leads to reduced performance.

A similar pattern of results emerged from partialing metacognitive strategies out of cognitive strategies and vice versa. First of all, removing metacognitive strategies from cognitive strategies improved the positive relation between cognitive strategies and achievement. This suggests that spending time organizing, planning, and monitoring learning detracts from the actual processing and learning of the language material.

Metacognitive strategies are so-called because they are "beyond, beside, or with the cognitive..."

[M]etacognitive strategies are actions which go beyond purely cognitive devices, and which provide a way for learners to coordinate their own learning process" (Oxford 1990: 136). Perhaps, however, the more time is spent coordinating the learning process, the less time is devoted strictly to active thinking about the language material itself. Indeed, when cognitive strategies were partialled out of metacognitive strategies, the relation between metacognitive strategies and achievement became negative, suggesting that only coordinating learning and not directly engaging in processing the language material results in relatively lower levels of attainment.

To some degree, then, the present findings appear to contravene the view that numerous strategies can facilitate SLA, and suggest that some strategies may actually work in opposition to each other to produce differential effects on L2 achievement. To the extent that the present results prove reliable, of course, the observations made here raise some issues that might be worthwhile for L2 instructors to consider. Indeed, there is a considerable literature devoted toward developing methods for teaching L2 learners how to use LLS effectively (cf. Chamot 1998; Dörnyei 1995; Heffernan 1998; Oxford 1993: 180-182), and it appears that the present results could inform such methods. In light of the present results, it may be advisable for L2 instructors to encourage their students to not rely too much on indirect language learning techniques such as managing emotion (affective strategies) and/or organizing and planning their learning (metacognitive strategies), at the expense of more active, direct mental processing of the language material (cognitive strategies). As Oxford (1990: 43; see also Oxford 1996b) maintains, cognitive strategies are "essential for learning a new language."

5.0 Limitations and Directions for Future Research

While the present results are noteworthy from both a theoretical and practical perspective, it is worthwhile to discuss the major limitations of our methodology. First of all, while the results of the SEM analyses are consistent with a number of the hypothesized relations, it is not appropriate to make firm inferences about causation given the correlational and cross-sectional nature of this study (see Breckler 1990). Further research using experimental and/or longitudinal designs is necessary to determine whether the causal process presented here is the appropriate one for the present variables. The second limitation is the small sample size available for the SEM analyses. Although it was higher than 100 (see Boomsma 1982), parameter estimates tend to be more stable in larger samples (e.g., 200 or greater; Ullman 1996). It should be noted, though, that ML estimation has been shown to be robust to small sample size (see Hoyle and Panter 1995), and also that the CFI and the RMSEA are relatively insensitive to sample size (e.g., Fan, Thompson, and Wang 1999). Therefore, it seems reasonable to assume that the present results still provide meaningful information. Nonetheless, it would be useful to repeat this study with a larger sample to determine further the reliability of the results. Finally, it is important to note the exploratory nature of the analyses examining the suppression effects involving L2 achievement and cognitive, affective, and metacognitive strategies. It is possible that these analyses were capitalizing on chance characteristics of the current sample and thus might not necessarily reflect the population of interest (university level language learners). Therefore, further research examining how different LLS might oppose and complement each other is necessary to determine the reliability of these findings.

6.0 Conclusions

Despite these limitations, the present results make some important contributions to existing knowledge about L2 learning and motivation. First of all, the results regarding NC demonstrate the value of continuing to integrate concepts from the general psychological and educational literature with L2 variables. Indeed, motivation is a very complex puzzle and L2 motivation is no exception. As Tremblay and Gardner (1995) point

out, there is certainly no individual model of motivation that can provide all of the necessary pieces (see also Landy and Becker 1987). Thus an ongoing synthesis of various motivational paradigms appears to have the most potential to expand our knowledge of L2 motivation as well as guide the development of methods to foster it. It is crucial, however, that such an integration involve careful formulation of the relations among variables (e.g., appropriate specification of mediating processes) in order to ensure that the models tested are substantively meaningful.

Second, the unanticipated findings regarding the relations between achievement and cognitive, affective, and metacognitive strategies show that the relationship between the use of LLS and L2 achievement is far from unequivocal. The present data indicate that certain LLS possess relative advantages and disadvantages that have yet to be fully understood. Future scientific inquiry will hopefully serve to more clearly delineate the nature of these unexpected results. Such research would not only serve to build on what is presently known about the properties of the various LLS, but may lead to the development of more effective methods for teaching students how to employ them (see Chamot 1998; Dörnyei 1995; Heffernan 1998; Oxford 1993: 180-182).

References

- Abramson, Lyn Y., Seligman, Martin E. P., & Teasdale, John D. (1978). Learned helplessness in humans: A critique and reformulation. *Journal of Abnormal Psychology, 87(1)*, 49-74.
- Bentler, Peter M. (1990). Comparative fit indexes in structural models. *Psychological Bulletin, 107(2)*, 238-246.
- Bentler, Peter M. (1998). *EQS structural equations program manual*. Encino, CA: Multivariate Software, Inc.
- Blanche, Patrick & Merino, Barbara J. (1998). Self-assessment of foreign-language skills: Implications for teachers and researchers. *Language Learning, 39(3)*, 313-340.
- Boomsma, Anne. (1982). The robustness of LISREL against sample size in factor analysis models. In K.G. Jöreskog & Herman Wold (Eds.). (1982). *Systems under indirect observation: Causality, structure, prediction* (Pt. 1, pp. 149-173). Amsterdam: North-Holland.
- Breckler, Steven J. (1990). Applications of covariance structure modeling in psychology: Cause for concern? *Psychological Bulletin, 107(2)*, 260-273.
- Browne, Michael. W. & Cudeck, Robert. (1993). Alternative ways of assessing model fit. In Kenneth.A.Bollen & J. Scott. Long (Eds.). (1993). *Testing structural equation models* (pp. 136-162). Newbury Park, CA: Sage.
- Brownlow, Sheila. Gilbert, Natalie M., & Reasinger, Renne D. (1999). Motivation, personality preferences, and interests in college students. *Journal of Psychological Science, 3(4)*, 128-140.
- Busato, Vittorio V., Prins, Frans J., Elshout, Jan J., & Hamaker, Christiaan. (2000). Intellectual ability, learning style, personality, achievement motivation and academic success of psychology students in higher education. *Personality and Individual Differences, 29(6)*, 1057-1068.
- Byrne, Barbara M. (1994). *Structural equation modeling with EQS and EQS/Windows: Basic concepts, applications, and programming*. Thousand Oaks, CA: Sage.
- Cacioppo, John T. & Petty, Richard E. (1982). The need for cognition. *Journal of Personality and Social Psychology, 42(1)*, 116-131.
- Cacioppo, John T., Petty, Richard E., Feinstein, Jeffrey A., & Jarvis, W. Blair G. (1996). Dispositional differences in cognitive motivation: The life and times of individuals varying in need for cognition. *Psychological Bulletin, 119(2)*, 197-253.
- Cacioppo, John T., Petty, Richard E., & Kao, Chuan F. (1984). The efficient assessment of the need for cognition. *Journal of Personality Assessment, 48(3)*, 306-307.

-
- Carrell, Patricia L., Prince, Moneta S., & Astika, Gusti G. (1996). Personality types and language learning in an EFL context. *Language Learning, 46(1)*, 75-99.
- Chamot, Anna U. (1998). *Teaching learning strategies to foreign students*. Washington, D.C.: Center for Applied Linguistics.
- Clément, Richard. (1980). Ethnicity, contact, and communicative competence in a second language. In Howard Giles, W. Peter Robinson, & Philip M. Smith (Eds.). (1980). *Language: Social psychological perspectives* (pp. 147-154). Oxford, England: Pergamon Press.
- Clément, Richard. (1986). Second language proficiency and acculturation: An investigation of the effects of language status and individual characteristics. *Journal of Language and Social Psychology, 5(4)*, 271-290.
- Clément, Richard. (1988). *Echelles d'attitude et de motivation reliées aux rapports inter-ethniques* [Scales of attitude and motivation related to inter-ethnic relations.] (Tech. Rep.), University of Ottawa, Ontario.
- Clément, Richard, Dörnyei, Zoltán, & Noels, Kimberly. A. (1994). Motivation, self-confidence, and group cohesion in the foreign language classroom. *Language Learning, 44(3)*, 417-448.
- Clément, Richard & Kruidenier, Bastian G. (1985). Aptitude, attitude and motivation in second language proficiency: A test of Clément's model. *Journal of Language and Social Psychology, 4(1)*, 21-37.

- Cohen, Andrew D. (1990). *Language learning: Insights for learners, teachers, and researchers*. Boston: Heinle & Heinle.
- Cohen, Jacob. (1994). The earth is round ($p < .05$). *American Psychologist*, 49(12), 997-1003.
- Cohen, Jacob & Cohen, Patricia. (1983). *Applied multiple regression/correlational analysis for the behavioral sciences* (2nd ed.). Hillsdale, NJ: Erlbaum.
- Crookes, Graham & Schmidt, Richard W. (1991). Motivation: Reopening the research agenda. *Language Learning*, 41(4), 469-512.
- Dansereau, Donald F. (1988). Cooperative learning strategies. In Claire E. Weinstein, Ernest T. Goetz, & Patricia A. Alexander (Eds.). (1988). *Learning and study strategies: Issues in assessment, instruction, and evaluation*. (pp. 103-120). New York: Academic Press.
- Deci, Edward L. & Ryan, Richard M. (1985). *Intrinsic motivation and self-determination in human behavior*. New York: Plenum Press.
- Deci, Edward L. & Ryan, Richard M. (1994). Promoting self-determined education. *Scandinavian Journal of Educational Research*, 38(1), 3-14.

-21-

- Deci, Edward L., Vallerand, Robert J., Pelletier, Luc G., & Ryan, Richard M. (1991). Motivation and education: The self-determination perspective. *The Educational Psychologist*, 26(3-4), 325-346.
- Dickinson, Leslie. (1995). Autonomy and motivation: A literature review. *System*, 23(2), 165-174.
- Dörnyei, Zoltan. (1994). Motivation and motivating in the foreign language classroom. *Modern Language Journal*, 78(3), 273-284.
- Dörnyei, Zoltan. (1995). On the teachability of communication strategies. *TESOL Quarterly*, 29(1), 55-85.
- Dörnyei, Zoltan. (1998). Motivation in second and foreign language learning. *Language Teaching*, 31, 117-135.
- Ehrman, Madeline E. (1990a). The role of personality type in adult language learning: An ongoing investigation. In Thomas S. Parry & Charles W. Stansfield (Eds.). (1990). *Language aptitude reconsidered* (pp. 126-178). Englewood Cliffs, NJ: Prentice-Hall.
- Ehrman, Madeline E. (1990b). Owls and doves: Cognition, personality, and learning success. In James E. Alatis (Ed.). (1990). *Linguistics, language teaching, and language acquisition: The interdependence of theory, practice, and research* (pp. 413-437). Washington, D.C.: Georgetown University Press.
- Ehrman, Madeline E. (1994). The type differentiation indicator and adult language learning success. *Journal of Psychological Type*, 30, 10-29.
- Ehrman, Madeline E. & Oxford, Rebecca L. (1989). Effects of sex differences, career choice, and psychological type on adult language learning strategies. *Modern Language Journal*, 73, 1-13.
- Ehrman, Madeline E. & Oxford, Rebecca L. (1995). Cognition plus: Correlates of language learning success. *Modern Language Journal*, 79(1), 67-89.
- Ellis, Rod. (1994). *The second language acquisition*. Oxford: Oxford University Press.
- Eysenck, Michael W. (1979). Anxiety, learning, and memory: A reconceptualization. *Journal of Research in Personality*, 13(4), 363-385.
- Fan, Xiato, Wang, Lin, & Thompson, Bruce. (1999). Effects of sample size, estimation method, and model specification on structural equation modeling fit indexes. *Structural Equation Modeling*, 6(1), 56-83.
- Fleming, Fay & Walls, Geoff. (1998). What pupils do: The role of strategic planning in modern foreign language learning. *Language Learning Journal*, 18, 14-21.
- Fortier, Michelle S., Vallerand, Robert J., & Guay, Frederic (1995). Academic motivation and school performance: Toward a structural model. *Contemporary Educational Psychology*, 20(3), 257-274.

-22-

- Furnham, Adrian. (1995). International handbook of personality and intelligence: Perspectives on individual differences. In Donald H. Saklofske & Moshe Zeidner (Eds.). (1995). *International handbook of personality and intelligence: Perspectives on individual differences* (pp. 397-413). New York: Plenum Press.

- Gaies, Steven J. (1985). *Peer involvement in language learning*. New York: Harcourt Brace Jovanovich.
- Gardner, Robert C. (1985). *Social psychology and second language learning: The role of attitudes and motivation*. London: Edward Arnold.
- Gardner, Robert C. (1988). The socio-educational model of second language learning: Assumptions, findings, and issues. *Language Learning, 38*, 101-126.
- Gardner, Robert C. (1990). Attitudes, motivation, and personality as predictors of success in foreign language learning. In Thomas Parry & Charles W. Stansfield (Eds.). (1990). *Language aptitude reconsidered* (pp. 179-221). Englewood Cliffs, NJ: Prentice-Hall.
- Gardner, Robert C., & MacIntyre, Peter D. (1993). A student's contributions to second language learning. Part II: Affective variables. *Language Teaching, 26*, 1-11.
- Gardner, Robert C., Tremblay, Paul F., & Masgoret, Anne-Marie. (1997). Towards a full model of second language learning: An empirical investigation. *Modern Language Journal, 81(3)*, 344-362.
- Giles, Howard & Byrne, Jane L. (1982). An intergroup approach to second language acquisition. *Journal of Multilingual and Multicultural Development, 3(1)*, 17-40.
- Green, John M. & Oxford, Rebecca L. (1995). A closer look at learning strategies, L2 proficiency, and gender. *TESOL Quarterly, 29(2)*, 261-297.
- Guay, Frederic & Vallerand, Robert J. (1997). Social context, student's motivation, and academic achievement: Toward a process model. *Social Psychology of Education, 1(3)*, 211-233.
- Heffernan, Peter J. (1998). Promoting the development of strategic competence in the language classroom. *Mosaic, 5(4)*, 1-8.
- Heilenman, L. Kathy. (1990). Self-assessment of second language ability: The role of response effects. *Language Testing, 7*, 174-201.
- Hoffman, Rich. (1995). Establishing factor validity using variable reduction in confirmatory factor analysis. *Educational and Psychological Measurement, 55(4)*, 572-582.

-23-

- Horwitz, Elaine K. & Young, Dolly. (Eds.). (1991). *Language anxiety: From theory and research to classroom implications*. Englewood Cliffs, NJ: Prentice-Hall.
- Hoyle, Rick H. (Ed.). (1995). *Structural equation modeling: Concepts, issues, and applications*. Thousand Oaks, CA: Sage.
- Hoyle, Rick H. & Panter, Abigail T. (1995). Writing about structural equation models. In R.H.Hoyle (Ed.). (1995). *Structural equation modeling: Concepts, issues, and applications* (pp. 158-176). Thousand Oaks, CA: Sage.
- Hu, Li-tze. & Bentler, Peter M. (1999). Cutoff criteria for fit indexes in covariance structure analysis: Conventional criteria versus new alternatives. *Structural Equation Modeling, 6(1)*, 1-55.
- Koestner, Richard, Zuckerman, Miron, & Olsson, Jennifer. (1990). Attributional style, comparison focus of praise, and intrinsic motivation. *Journal of Research in Personality, 24(1)*, 87-100.
- Landy, Frank J. & Becker, Wendy S. (1987). Motivation theory reconsidered. *Research in Organizational Behavior, 9*, 1-38.
- Lazarus, Richard S. & Folkman, Susan. (Eds.). (1984). *Stress, appraisal, and coping*. New York: Springer.
- Leone, Christopher & Dalton, Charles H. (1988). Some effects of the need for cognition on course grades. *Perceptual and Motor Skills, 67(1)*, 175-178.
- MacIntyre, Peter D. (1995). How does anxiety affect language learning? A reply to Sparks and Ganschow. *Modern Language Journal, 79(1)*, 91-99.
- MacIntyre, Peter D. & Charos, Catherine. (1996). Personality, attitudes, and affect as predictors of second language communication. *Journal of Language and Social Psychology, 15(1)*, 3-26.
- MacIntyre, Peter D. & Gardner, Robert C. (1989). Anxiety and second language learning: Toward a theoretical clarification. *Language Learning, 39(2)*, 251-275.
- MacIntyre, Peter D. & Gardner, Robert C. (1991). Methods and results in the study of foreign language anxiety: A review of the literature. *Language Learning, 41(1)*, 85-117.

- MacIntyre, Peter D. & Gardner, Robert C. (1994). The effects of induced anxiety on three stages of cognitive processing in computerized vocabulary learning. *Studies in Second Language Acquisition*, 16(1), 1-17.
- MacIntyre, Peter D., & Noels, Kimberly A. (1996). Using social-psychological variables to predict the use of language learning strategies. *Foreign Language Annals*, 29(3), 373-386.
- MacIntyre, Peter D., Noels, Kimberly A., & Clément, Richard. (1997). Biases in self-ratings of second language proficiency. *Language Learning*, 47(2), 265-287.

-24-

- Marcoulides, George A. & Schumacker, Randall E. (Eds.). (1996). *Advanced structural equation modeling: Issues and techniques*. Mahwah, NJ: Erlbaum.
- McRae, Robert R. & Costa, Paul T., Jr. (1996). Toward a new generation of personality theories: Theoretical contexts for the five-factor model. In Jerry S. Wiggins (Ed.). (1993). *The five-factor model of personality: Theoretical perspectives* (pp. 51-87). New York: Guilford Press.
- McCroskey, James C. & Richmond, Virginia P. (1991). Willingness to communicate: A cognitive view. In Melanie Booth-Butterfield (Ed.). (1991). *Communication, cognition, and anxiety* (pp. 19-37). Newbury Park, CA: Sage.
- Myers, Isabel B. (1987). *Introduction to type* (4th ed.). Palo Alto, CA: Consulting Psychologists Press.
- Noels, Kimberly A. (2001a). Learning Spanish as a second language: Learners' orientations and perceptions of teachers' communicative style. *Language Learning*, 51(1), 107-144.
- Noels, Kimberly A. (2001b). New orientations in language learning motivation: Towards a model of intrinsic, extrinsic and integrative orientations. In Zoltan Dornyei & Richard W. Schmidt (Eds.). (2001). *Motivation and second language acquisition* (pp. 43-68). Honolulu, HI: University of Hawai'i Second Language Teaching and Curriculum Centre.
- Noels, Kimberly A., Clément, Richard, & Pelletier, Luc. (1999). Perceptions of teachers' communicative style and students' intrinsic and extrinsic motivation. *Modern Language Journal*, 83(1), 24-34.
- Noels, Kimberly A., Clément, Richard, & Pelletier, Luc. (2001). Intrinsic, extrinsic, and integrative orientations of French Canadian learners of English. *Canadian Modern Language Review*, 57(3), 424-442.
- Noels, Kimberly A., Pelletier, Luc, Clément, Richard, & Vallerand, Robert J. (2000). Why are you learning a second language? Motivational orientations and self-determination theory. *Language Learning*, 50 (1), 57-85.
- Olson, Kenneth, Camp, Cameron, & Fuller, Dana. (1984). Curiosity and need for cognition. *Psychological Reports*, 54(1), 71-74.
- O'Malley, J. Michael & Chamot, Anna. (1990). *Learning strategies in second language acquisition*. Cambridge: Cambridge University Press.
- Oxford, Rebecca L. (1990). *Language learning strategies: What every teacher should know*. New York: Harper Collins.
- Oxford, Rebecca L. (1993). Research on second language learning strategies. *Annual Review of Applied Linguistics*, 13, 175-187.

-25-

- Oxford, Rebecca L. (Ed.). (1996a). *Language learning motivation: Pathways to the new century*. Honolulu: University of Hawaii Press.
- Oxford, Rebecca L. (1996b). Employing a questionnaire to assess the use of language learning strategies. *Applied Language Learning*, 7(1-2), 25-45.
- Oxford, Rebecca L. & Burry-Stock, Judith A. (1995). Assessing the use of language learning strategies worldwide with the ESL/EFL version of the Strategy Inventory for Language Learning (SILL). *System*, 23(1), 1-23.
- Oxford, Rebecca L. & Cohen, Andrew D. (1992). Language learning strategies: Crucial issues in concept and classification. *Applied Language Learning*, 3(1-2), 1-35.
- Oxford, Rebecca L. & Crookall, David. (1989). Research on language learning strategies: Methods, findings, and instructional implications. *Modern Language Journal*, 73(4), 404-419.

- Oxford, Rebecca L. & Ehrman, Madeline E. (1995). Adults' language learning strategies in an intensive foreign language program in the United States. *System*, 23(3), 359-386.
- Oxford, Rebecca L. & Nyikos, Martha. (1989). Variables affecting choice of language learning strategies by university students. *Modern Language Journal*, 73(3), 291-300.
- Oxford, Rebecca L., Park-Oh, Young, Ito, Sukero, & Sumrall, Malenna. (1993). Japanese by satellite: Effects of motivation, language learning styles and strategies, gender, course level, and previous language learning experience on Japanese language achievement. *Foreign Language Annals*, 26(3), 359-371.
- Oxford, Rebecca L. & Shearin, Jill. (1994). Language learning motivation: Expanding the theoretical framework. *Modern Language Journal*, 78(1), 12-28.
- Park, Gi-Pyo. (1997). Language learning strategies and English proficiency in Korean university students. *Foreign Language Annals*, 30(2), 211-221.
- Pedhazur, Elazar J. (1997). *Multiple regression in behavioral research: Explanation and prediction* (3rd ed.). New York: Holt, Rinehart, & Winston.
- Revelle, William. (1993). Individual differences in personality and motivation: 'Non-cognitive' determinants of cognitive performance. In Alan D. Baddeley & Lawrence Weiskrantz (Eds.). (1993). *Attention, selection, awareness, and control: A tribute to Donald Broadbent* (pp. 346-373). Oxford: Oxford University Press.
- Ryan, Richard M. & Deci, Edward L. (2000a). Self-determination theory and the facilitation of intrinsic motivation, social development, and well-being. *American Psychologist*, 55(1), 68-78.
- Ryan, Richard M. & Deci, Edward L. (2000b). Intrinsic and extrinsic motivations: Classic definitions and new directions. *Contemporary Educational Psychology*, 25(1), 54-67.
- Sadowski, Cyril J. & Gulgoz, Sami. (1992). Association of need for cognition and course performance. *Perceptual and Motor Skills*, 74, 498-498.

-26-

- Sadowski, Cyril J. & Gulgoz, Sami. (1996). Elaborative processing mediates the relation between need for cognition and academic performance. *Journal of Psychology*, 130, 303-307.
- Sarason, Irwin G. (1986). Test anxiety, worry, and cognitive interference. In Ralf Schwarzer (Ed.). (1986). *Self-related cognition in anxiety and motivation* (pp. 19-34). Hillsdale: Erlbaum.
- Schumann, John H. (1978). The acculturation model for second language acquisition. In Rosario C. Gingras (Ed.). (1978). *Second language acquisition and foreign language teaching* (pp. 27-50). Arlington, VA: Center for Applied Linguistics.
- Skehan, Peter. (1989). *Individual differences in second language learning*. London: Edward Arnold.
- Slavin, Robert E. (1980). Cooperative learning. *Review of Educational Research*, 50(2), 315-342.
- Slavin, Robert E. (1983). *Cooperative learning*. New York: Longman.
- Stark, Joan S., Bentley, Richard J., Lowther, Malcom A., & Shaw, Kathleen M. (1991). The Student Goals Exploration: Reliability and concurrent validity. *Educational and Psychological Measurement*, 51(2), 413-422.
- Steiger, James H. (1990). Structural model evaluation and modification: An interval estimation approach. *Multivariate Behavioral Research*, 25(2), 173-180.
- Tabachnick, Barbara G. & Fidell, Linda S. (1996). *Using multivariate statistics* (3rd ed.). New York: Harper Collins.
- Talbot, Gilles L. (1990). Personality correlates and personal investment of college students who persist and achieve. *Journal of Research and Development in Education*, 24(1), 53-57.
- Tobias, Sigmund. (1986). Anxiety and cognitive processing of instruction. In Ralf Schwarz (Ed.). (1986). *Self-related cognition in anxiety and motivation* (pp. 35-54). Hillsdale, NJ: Erlbaum.
- Tremblay, Paul F. & Gardner, Robert C. (1995). Expanding the motivation construct in language learning. *Modern Language Journal*, 79(4), 505-518.
- Ullman, Jodie B. (1996). Structural equation modeling. In Barbara G. Tabachnick & Linda S. Fidell (Eds.). (1996). *Using multivariate statistics* (pp. 709-811). New York: Harper Collins.
- Vallerand, Robert J. (1997). Toward a hierarchical model of intrinsic and extrinsic motivation. In Mark P. Zanna (Ed.). (1997). *Advances in experimental social psychology* (vol. 29) (pp. 271-360). San Diego, CA:

Academic Press.

Vallerand, Robert J., Fortier, Michelle S., & Guay, Frederic. (1997). Self-determination and persistence in a real-life setting: Toward a motivational model of high-school dropout. *Journal of Personality and Social Psychology, 72*(5), 1161-1176.

-27-

- Vallerand, Robert J., Pelletier, Luc G., Blais, Marc R., Brière, Nathalie M., Senécal, Caroline, & Vallières, Evelyne F. (1992). The Academic Motivation Scale: A measure of intrinsic, extrinsic, and amotivation in education. *Educational and Psychological Measurement, 52*(4), 1003-1017.
- Vallerand, Robert J., Pelletier, Luc G., Blais, Marc R., Brière, Nathalie M., Senécal, Caroline, & Vallières, Evelyne F. (1993). On the assessment of intrinsic, extrinsic, and amotivation in education: Evidence on the concurrent and construct validity of the Academic Motivation Scale. *Educational and Psychological Measurement, 53*(1), 159-172.
- Venkatraman, Meera P., Marlino, Deborah, Kardes, Frank R., & Sklar, Kimberly B. (1990). Effects of individual difference variables on response to factual and evaluative ads. *Advances in Consumer Research, 17*, 761-765.
- Venkatraman, Meera P. & Price, Linda L. (1990). Differentiating between cognitive and sensory innovativeness. *Journal of Business Research, 20*, 293-315.
- Wang, Alvin Y. & Newlin, Michael H. (2000). Characteristics of students who enroll and succeed in psychology Web-based classes. *Journal of Educational Psychology, 92* (1), 137-143.
- Waschull, Stefanie B. & Kernis, Michael H. (1996). Level and stability of self-esteem as predictors of children's intrinsic motivation and reason for anger. *Personality and Social Psychology Bulletin, 22*(1), 4-13.
- Williams, Marion. (1994). Motivation in foreign and second language learning: An interactive perspective. *Educational and Child Psychology, 11*(2), 77-84.
- Yuan, Ke-Hai., Bentler, Peter M., & Kano, Yutaka. (1997). On averaging variables in a confirmatory factor analysis model. *Behaviormetrika, 24*(1), 71-83.

Notes

[1] This paper is based on part of an M. A. thesis project conducted by the first author under the supervision of the second author at the University of Saskatchewan. Financial support for this project was provided by a grant to the second author from the Social Sciences and Humanities Research Council of Canada. The authors would like to thank the faculty members of the University of Saskatchewan Department of Languages and Linguistics for their cooperation in this project, as well as the students for their participation. Further thanks are due to Kristie Saumure, MA, for her invaluable assistance with the preparation of the final version of this manuscript.

[2] Correspondence concerning this article can be sent to Cameron N. McIntosh, now with the Health Analysis and Measurement Group, Statistics Canada, 24-A R.H. Coats Building, Ottawa, Ontario, Canada, K1A 0T6; e-mail: cameron.mcintosh@statcan.ca, or to Kimberly A. Noels, Department of Psychology, University of Alberta, Edmonton, Canada, T6G 2E9; email: knoels@ualberta.ca.

-28-

[3] It is worthwhile to point out that while self-perceptions of L2 competence were used as a replacement for actual achievement in the model due to concerns about sample size, there were no significant relationships among the four self-ratings of L2 competence and final course grades (see Table 2). While these correlations were estimated using only a subset ($n = 65$) of the sample used for the SEM analyses ($N = 126$), they do raise questions about the appropriateness of using self-ratings of proficiency as a substitute for more objective indices of achievement. Indeed, research has shown that L2 learners tend to both overestimate and underestimate their actual L2 competence (defined by objective measures of achievement; see Heilenman, 1990; MacIntyre, Noels, & Clément, 1997). MacIntyre et al. (1997) demonstrated language anxiety to be empirically linked to systematic over and underestimation of L2 competence. It is also important to point out, however, that both actual and perceived L2 competence have typically been found to be correlated (e.g., MacIntyre et al., 1997), particularly when there is a high degree of specificity between the self-rating of proficiency and the L2 task on which performance is to be other-rated (cf. Blanche & Merino, 1989). It is possible that there was a lack of specificity between the self-ratings of L2 proficiency used in the present study and overall course performance; nonetheless, it does seem unusual that not even a modest correlation was found between these two variables. It is difficult to determine why actual and perceived L2 competence were uncorrelated in the present subsample used for the hierarchical regression analysis. Thus these results warrant additional examination of the association between perceived and actual L2 competence in order to further determine the conditions under which these two variables will and will not be related.

APPENDIX (in Word format)

Copyright © 2004 *Zeitschrift für Interkulturellen Fremdsprachenunterricht*

<p>McIntosh, Cameron N. and Noels, Kimberly A. (2004). Self-Determined Motivation for Language Learning: The Role of Need for Cognition and Language Learning Strategies. <i>Zeitschrift für Interkulturellen Fremdsprachenunterricht</i> [Online], 9(2), 28 pp. Erhältlich unter http://www.ualberta.ca/~german/ejournal/Mcintosh2.htm</p>
--

[Zurück zur [Leitseite](#)]