

Work Extrinsic and Intrinsic Motivation Scale: Its Value for Organizational Psychology Research

Maxime A. Tremblay, Céline M. Blanchard,
Sara Taylor, and Luc G. Pelletier
University of Ottawa

Martin Villeneuve
Department of National Defence, Ottawa, Ontario, Canada

The Work Extrinsic and Intrinsic Motivation Scale (WEIMS) is an 18-item measure of work motivation theoretically grounded in self-determination theory (Deci & Ryan, 2000). The purpose of the present research was twofold. First, the applicability of the WEIMS in different work environments was evaluated. Second, its factorial structure and psychometric properties were assessed. Two samples of workers (military: $N = 465$; civilians: $N = 192$) voluntarily completed questionnaires. Using the WEIMS's 3 indexes (work self-determination index, work self-determined and nonself-determined motivation, respectively), results of regression analyses were supportive of its ability to predict positive and negative criteria in the workplace. Results also showed the adequacy of both its construct validity and internal consistency. Its factorial structure was also invariant across samples. Finally, its quasi-simplex pattern and relationships with psychological correlates further supported the self-determination continuum. Overall, these findings provide evidence for the applicability as well as the reliability and validity of the WEIMS in organisational settings. Results are discussed in regard to the applicability of self-determination theory to the workplace.

Keywords: work motivation, self-determination theory, scale validation

Work motivation is an enigmatic topic in work and organisational science (Kanfer, Chen, & Pritchard, 2008). Given today's economy, a motivated workforce represents both a competitive advantage and a critical strategic asset in any work environment. In organisational research, work motivation has been the subject of more theories than any other topic (Baron, 1991); organisational researchers see employee motivation as a fundamental building block in the development of effective theories (Steers, Mowday, & Shapiro, 2004). Indeed, programs of research guided by expectancy-valence theory, self-regulation and goal-setting formulations, social exchange and justice approaches, and self-perspective (e.g., self-determination theory [SDT]; Deci & Ryan, 1985, 2000) have stimulated the development of organisational and managerial practises to promote positive worker attitudes (e.g., employee commitment) and enhance job performance (e.g., individual and team effort).

An issue that warrants attention in motivation research is the method and approach used to assess this construct. Assessments of employee motivation need to be practical, fast, flexible, and accessible through different means. Short, theory-grounded measures leading to concrete applied venues are key to addressing these organisational needs. This paper will thusly define and review different approaches to studying and assessing motivation in the

workplace. Emphasis will be given to a subjective approach grounded in SDT, which should prove valuable and practical for use in rapidly changing organisational environments.

Definition and Types of Motivation Measure

Pinder (1998) defined *work motivation* as “a set of energetic forces that originates both within as well as beyond an individual's being, to initiate work-related behaviour, and to determine its form, direction, intensity and duration” (p. 11). Motivation is thusly manifested by attention, effort, and persistence. The ability to measure factors that energize, channel, and sustain work behaviour over time (Steers et al., 2004), is essential for capturing employee motivation and for developing interventions aimed at enhancing motivation, and in turn, job satisfaction and performance. To date, most research on the influence of individual factors in work motivation has investigated differences that can be captured through self-report measures of personality, affect, interests, and values (Kanfer et al., 2008). Within the organisational psychology literature, there are four major measurement systems used to assess work motivation. These include projective, objective, implicit/explicit, and subjective measures.

The hallmark of a projective assessment is presenting the individual with an ambiguous stimulus and eliciting a fairly unstructured response. As they apply to motivation, the vast majority are designed to measure motivational needs, motives, or personality traits (e.g., Thematic Apperception Test; Murray, 1943), but rarely states or processes. Although there is arguably some support for their criterion-related validity (e.g., Miner, 2002), their construct validity is dependent on such boundary conditions as ensuring that the criteria correspond to the underlying theory (e.g., Ployhart, Schneider, & Schmitt, 2006). Their use in organisational settings

Maxime A. Tremblay, Céline M. Blanchard, Sara Taylor, and Luc G. Pelletier, School of Psychology, University of Ottawa; Martin Villeneuve, Department of National Defence, Ottawa, Ontario, Canada.

Correspondence concerning this article should be addressed to Maxime A. Tremblay, School of Psychology, University of Ottawa, 145 Jean-Jacques Lussier, Montpetit 416 A, Ottawa, Ontario, Canada, K1N 6N5. E-mail: mtrem001@uottawa.ca

has also diminished in the past few decades because they are not necessarily specific to the domain of work (Ployhart, 2008).

Because objective measures minimise human judgement relative to projective measures, many researchers prefer them (e.g., psychomotor measures such as pursuit rotor and finger tapping; see Kanfer & Heggstad, 1997). However, although their reliability is frequently high, a meta-analysis suggests this is not always the case (Roth, Huffcutt, & Bobko, 2003). There can be problems due to low baseline rates, strong influences by environmental factors, and criterion deficiency (Ployhart, 2008). The assessment of behavioural indicators of work motivation also makes it challenging to delineate what is unique to motivation and what belongs to the consequences (e.g., organisational identification and job satisfaction; Weege, Van Dick, Fisher, Wecking, & Moltzen, 2006). Although objective assessments can be a useful way to measure choice, effort, and persistence, simply using a measure because it is objective does not make it construct valid, or more valid than any other alternative (Ployhart, 2008).

From a theoretical perspective, there is growing convergence amongst motivation scholars for the use of implicit (subconscious) processes (e.g., James & Mazerolle, 2002; Kehr, 2004; Locke & Latham, 2004). A key feature of implicit measures (e.g., Implicit Attitude Test; Greenwald & Banaji, 1995) is that the individual tends not to know (or be aware of) what is being measured, therefore minimising socially desirable responses. Implicit measures are thus ideally suited for assessing socially unpopular, sensitive, or controversial topics as well as unconscious goals (see Johnson & Steinman, 2009). A drawback of using implicit measures is that they do not allow researchers to identify an individual's true scores on latent constructs (Blanton & Jaccard, 2006). In addition, the correlations between objective and subjective measures are often low, suggesting the assessment of distinct phenomena (Thierry, 1990). The development of a valid measure of conscious work motives, based on theory, remains a critical step toward these new lines of research.

Last, but not least, self-report measures are the most commonly used measure of an employee's motivation. Nevertheless, contamination in subjective measures can also come from several sources. For example, common-source bias occurs when the same participants complete all of the measures in a study, whereas common-method bias occurs when all measures are of the same type (e.g., self-report) or assessed at the same time. Arguably they can result in biased effect sizes (i.e., inflation or attenuation), although some researchers do not believe the results are always damaging (Ployhart, 2008).

Studies on individual differences in work motivation have been investigated using peer ratings (Landy & Guion, 1970). Others have documented individual differences within the framework of Deci and Ryan's (1985; Ryan & Deci, 2002) SDT. This includes satisfaction with a given task and intentions to continue (as indicated on questionnaires; Thierry, 1990). In the early 1990s, Blais, Lachance, Vallerand, Brière, and Riddle (1993) were amongst the first to provide empirical support for a SDT-based self-assessment of work motivation. They developed a French instrument, "*L'Inventaire des Motivations au Travail de Blais*" (Blais Inventory of Work Motivation; BIWM). To this date, no one has developed and validated an English version of this inventory.

Self-Determination Theory

SDT focuses on the "nature" of motivation, that is, the "why of behaviour." The underlying assumption is that "human beings are active, growth-oriented organisms who are naturally inclined toward integration of their psychic elements into a unified sense of self and integration of themselves into larger social structures" (Deci & Ryan, 2000, p. 229). Although psychological growth and integration tendencies are natural, they are susceptible to social and environmental conditions which can either support propensities for self-determination or disrupt them (Ryan & Deci, 2002).

SDT generally applies to activities that people find interesting, optimally challenging, or aesthetically pleasing. Activities, which are not experienced as such, work for example, are unlikely to be performed unless there is, to some extent, an extrinsic reason for doing them (Deci & Ryan, 2002). Consequently, SDT distinguishes between intrinsic motivation (i.e., doing an activity for its own sake because one finds the activity inherently interesting and satisfying) and extrinsic motivation (i.e., doing an activity for an instrumental reason). There are different types of extrinsic motivation that can be relatively controlled by external factors or that can be relatively autonomous (i.e., self-regulated through an individual's acquired goals and values). These types of motivation can be aligned along a continuum, that is, a quasi-simplex pattern (Ryan & Connell, 1989) representing the degree to which goals/values have been internalised (Ryan & Deci, 2002).

At the low-end lies amotivation (AMO) in which individuals either lack the intention to act or act passively. Next along the continuum is external regulation (ER), namely, doing an activity only to obtain a reward. Next is introjected regulation (INTRO), namely the regulation of behaviour through self-worth contingencies (e.g., self-esteem, guilt). Then there is identified regulation (IDEN), which refers to doing an activity because one identifies with its value or meaning, and accepts it as one's own. Finally, there is integrated regulation (INTEG), which refers to identifying with the value of an activity to the point that it becomes part of the individual's sense of self. This is the form of extrinsic motivation that is most fully internalised and hence is said to be autonomous.

Identification, integration, and intrinsic motivation are the prototype of self-determined motivations whereas amotivation, external regulation, and introjection are categorized as nonself-determined motivations. SDT does not presuppose that the self-determination continuum is a developmental one in the sense that individuals progress along it in specific stages. Rather, a new behaviour may be internalised at any point along the continuum depending on factors such as organisational context and an individual's prior experiences (Ryan, 1995).

Motivational Correlates

The self-determination continuum is useful for predicting "optimal functioning." Optimal functioning in organisations includes employee engagement, job performance subjective well-being, and retention (Gagné & Forest, 2008). SDT states that intrinsic motivation leads to the most positive consequences, followed by integrated and identified regulations. Introjected and external regulations lead to negative outcomes. Amotivation results in the most negative consequences (Vallerand & Ratelle, 2002). These negative outcomes may include counterproductive performance and employee withdrawal.

Most studies on SDT have been validated in nonorganisational settings (e.g., Academic Motivation Scale: Vallerand, Blais, Brière, & Pelletier, 1989; Leisure Motivation Scale: Pelletier, Vallerand, Blais, Brière, & Green-Demers, 1996) Blais and his colleagues (1993) were the first to provide empirical support for the effect of the self-determination continuum in a work setting, using their French 31-item BIWM. Their results indicated that external and introjected regulations were associated with emotional exhaustion, and physical and mental health problems (see also Houkes, Jassen, de Jonge, & Bakker, 2003). Self-determined types of motivation were also shown to display positive associations with job and life satisfaction (see also Locke & Latham, 2004).

Gagné and Deci (2005) argued that a supportive work climate satisfied the fundamental psychological needs of autonomy, competence, and relatedness postulated by SDT (Deci & Ryan, 1985). Such climate affects employees' intrinsic motivation and, in turn, increases organisational citizenship behaviours. Autonomy-supportive interpersonal styles have been shown to enhance intrinsic motivation and, in turn, such positive work-related outcomes as subordinates' perceptions, affects, and satisfactions (e.g., Deci, Connell, & Ryan, 1989; Zuckerman, Porac, Lathin, Smith, & Deci, 1978). In their respective integrative models of work motivation, both Locke and Latham (2004) and Meyer, Becker, and Vandenberghe (2004) proposed theoretical associations between work motivation, job involvement, and organisational commitment. Better job performance, employee engagement, subjective well-being, and employee retention also have been studied as indicators of optimal functioning in the workplace (e.g., Baard, Deci, & Ryan, 2004; Meyer & Gagné, 2008).

On the other hand, negative outcomes that have been researched in terms of their associations with low work motivation include depression (e.g., Blais et al., 1993) and turnover intentions (e.g., Quast & Kleinbeck, 1990). For instance, specific relationships between low intrinsic motivation, job burnout, and voluntary turnover intentions have been found in samples of bank employees and teachers (Houkes, Janssen, de Jonge, & Nijhuis, 2001). Although there is relatively little previous work relating SDT concepts to workplace deviance, (contrasting) evidence does indicate that autonomous motivation promotes volunteering and other prosocial behaviours (e.g., Gagné, 2003) and thusly, presumably would predict lower workplace defiant behaviours. These results are quite promising. Thusly it would appear important to evaluate an English version of the BIWM using a self-report approach to measuring work motivation. Doing so would allow the English research community to assess the multidimensional aspects of motivation. To date, very few theory-driven self-report measures of employee motivation are available for researchers and practitioners. The measures that do exist are often limited to intrinsic motivation (Hackman & Oldham, 1975; Warr, Cook, & Wall, 1979). Although the French version of the BIWM has demonstrated adequate psychometric properties (Blais et al., 1993; Vallerand, 1997), the constructs it measures are tapped by 31 items. This increases both scale complexity and participants' completion time. Moreover, Ryan and Deci's (2002) concept of integration (i.e., when identification by an individual has been evaluated and brought into congruence with the person's values, goals, and needs) was introduced after Blais et al.'s validation of their instrument and, thusly, cannot be measured with the current

BIWM. It is in part for these reasons that inspired by Blais's original work, a new organisational research tool assessing work motivation was developed.

Overview of Studies

The purpose of this research was to test the applicability (and versatility) of the WEIMS in different work environments as well as to evaluate its factorial structure and psychometric properties. Three studies were conducted,

- Study 1 assessed the six-factor, three-indicator factorial structure of the WEIMS using confirmatory factor analysis. Its internal consistency and construct validity were also examined.
- Study 2 assessed psychological constructs (both antecedents and consequences) hypothesised to be related to work motivation; and
- Study 3, together with Study 2, assessed the criterion validity of the WEIMS for predicting positive and negative work-related consequences using three indexes: the self-determination index and the two forms of motivation (i.e., self-determined and nonself-determined motivation). Its factorial invariance was also examined.

Preliminary Validation Steps

To develop the 18-item WEIMS, the best three manifest measurement indicators (items) of each of the five BIWM's original constructs,¹ were adapted using a back-to-back retranslation technique (Vallerand, 1989). Following this adaptation step, the WEIMS's 18 items were put to the test of an exploratory factor analysis (EFA) using a sample of Anglophone health care workers (100 women and 9 men; mean age = 44). The results of this EFA (maximum likelihood extraction with oblique rotation) were conclusive. The six-factor structure of the WEIMS was supported, with three items (per latent construct) serving as indicators. All 18 items had loadings higher than .30 (Tabachnick & Fidell, 2001). Moreover, every item loaded on their respective latent construct (eigenvalues greater than 1): intrinsic motivation (IM4 = .41; IM8 = .34; IM15 = .40), integrated regulation (INTEG5 = .44; INTEG10 = .41; INTEG18 = .42), identified regulation (IDEN1 = .45; IDEN7 = .63; IDEN14 = .33), introjected regulation (INTRO6 = .44; INTRO11 = .38; INTRO13 = .56), external regulation (EXT2 = .87; EXT9 = .82; EXT16 = .70), and amotivation (AMO3 = .36; AMO12 = .44; AMO17 = .34). Based on these preliminary results, the WEIMS is a shorter version of the French questionnaire and yet assesses all six motivational constructs postulated by SDT.

¹ Examples are as follows: IM4 « Parce que j'ai beaucoup de plaisir à apprendre de nouvelles choses dans ce travail »; IDEN7 « Parce que c'est le type de travail que j'ai choisi pour réaliser mes projets de carrière »; INTRO11 « Parce que je tiens absolument à être très bon(ne) dans ce travail, sinon je serais déçu(e) »; EXT9 « Parce que cela me permet de faire de l'argent »; AMO12 « Je ne le sais pas, on nous fixe des conditions de travail irréalistes ». The integration items were generated based on the Global Motivation Scale (Guay, Blais, Vallerand, & Pelletier, 1999). An example of item adaptation from global to work is: INTEG5 "Because they reflect what I value most in life" into "Because it has become a fundamental part of who I am."

Study 1 and Study 2

As noted above, the objectives of Study 1 were threefold: (a) the factorial structure of the WEIMS was examined through confirmatory factor analysis, (b) the internal consistencies of the six motivational subscales were assessed, and (c) the construct validity of the WEIMS was examined by conducting item-to-total inter-correlations as well as correlations amongst the subscales. It was hypothesised that each of the 18 indicators of the WEIMS would respectively load on six separate latent constructs (i.e., three items per factor). Moreover, the scale was expected to show adequate to excellent item-to-item consistency, along with midrange-to-high item-to-total correlations. Finally, based on Ryan and Connell's (1989) research, the WEIMS's quasi-simplex pattern of relationships was expected to display a self-determination continuum in which adjacent subscales show strong positive correlations (e.g., INTEG and IDEN), whereas subscales at opposite ends of the continuum display the most negative correlations (i.e., IM and AMO).

Study 2 was designed to present the first of two ways of using the WEIMS for prediction purposes, namely the work self-determination index (W-SDI). It was hypothesised that perceived organisational support and work climate would be predicted by the W-SDI. It was also anticipated that higher W-SDI would positively relate to job satisfaction and organisational commitment, and negatively associate with work strain and turnover intentions. Finally, it was hypothesised that lower W-SDI would show the reverse pattern of relationships.

A final objective of Study 2 was to examine the associations between each type of motivation and work-related antecedents and consequences. As evidence of criterion validity, it was hypothesised that work self-determined types of motivation (i.e., IM, INTEG, IDEN) would positively correlate with the antecedents (i.e., organisational support and work climate), job satisfaction and organisational commitment, as well as negatively correlate with work strain and turnover intentions; that the first two types of work nonself-determined motivation (i.e., INTRO, EXT) would show relatively low correlations with these same variables and that amotivation would demonstrate the reverse pattern of relationships.

Method

Participants and Procedure

A sample of 600 Regular Force military members across Canada received the Omnibus Survey of the Canadian Forces (CF). The survey sample was derived by a random stratified sampling procedure intended to accurately reflect particular demographic characteristics, regarding gender, rank, and language. Participants were invited to complete the survey and mail it to the CF's Director of Human Resources. Return envelopes and postage were provided. Participation in the survey was voluntary, and the anonymity and confidentiality of responses were assured. A total of 465 CF members returned the completed surveys for a response rate of 77.5%.

For validation purposes, the CF sample was divided into two groups, using the SPSS' (version 11.5) random selection of cases option. One group was assigned to either the construct validation phase of the WEIMS (Study 1), or to its content validity assess-

ment (Study 2). Unique data files were thusly used for different phases of validation. By doing so, sample-specific bias that may result in performing both confirmatory factor analysis (CFA) and correlations with dependent participants was minimised. Consequently, the sample for Study 1 ($N = 205$) consisted of 166 men and 21 women (18 individuals did not report their gender) from which 90.6% were English-speaking Regular Force members (72.9%) who had been serving in the CF for an average of 18.16 years. Study 2 ($N = 260$) was also comprised of Regular Force members (77.3%) of which 223 were men and 21 were women (16 individuals omitted to indicate their gender; 89.6% English²; 18.20 years of CF service).

Measures

Work Motivation

Participants completed the 18-item WEIMS (see Appendix A). The WEIMS is divided into three-item six subscales, which correspond to the six types of motivation postulated by SDT (i.e., intrinsic motivation, integrated, identified, introjected and external regulations, and amotivation). Participants were asked to indicate on a Likert-type scale³ ranging from 1 (*does not correspond at all*) to 5 (*corresponds exactly*) the extent to which the items represent the reasons they are presently involved in their work.

Although most researchers favour a multidimensional approach to (work) motivation, the use of a single score, such as the work self-determination index (W-SDI; Vallerand, 1997), is at times be desirable. The W-SDI may be particularly useful when researchers want to select individuals who display either a self-determined or a nonself-determined motivational profile. The WEIMS can be used to generate that index by multiplying the mean of each subscale by weights corresponding to the underlying level of self-determination (Ryan & Connell, 1989). The formula for determining the W-SDI is as follows: $W-SDI = (+3 \times IM) + (+2 \times INTEG) + (+1 \times IDEN) + (-1 \times INTRO) + (-2 \times EXT) + (-3 \times AMO)$. The range of possible scores on the W-SDI is between ± 36 for a 7-point Likert-type scale (and ± 24 when using a 5-point Likert-type scale). The total score derived from this formula reflects individuals' relative level of self-determination. A positive score indicates a self-determined profile and a negative score indicates a nonself-determined profile. Previous research has shown that the self-determination index displays high levels of reliability and validity (e.g., Fortier, Vallerand, & Guay, 1995; Green-Demers, Pelletier, & Ménard, 1997; Pelletier, Dion, Slovinec-D'Angelo, & Reid, 2004). The internal consistency (Cronbach's alpha coefficient) of the W-SDI was .84.

Perceived Organisational Support

The short version of the Survey of Perceived Organisational Support (Eisenberg, Huntington, Hutchison, & Sowa, 1986) was

² The approximate 10% of remaining participants on both samples who did not indicate English as their first language were for the majority French. To get a job offer in most departments of the federal government, a bilingual fluency is often required.

³ For conceptual purposes, the Omnibus Survey of the CF had a framework consisting of only 5-point Likert-type scales (or less). For this reason, the original 7-point scale was reduced to a 5-point scale for this sample.

used to measure CF members' perceptions of being appreciated and cared for by their organisation. It consists of 16 Likert-type items for which responses can range from 1 (*do not agree at all*) to 5 (*agree completely*). The internal consistency for this motivational antecedent was .90.

Work Climate

Organisational climate was defined as members' perceptions of how they are being treated by their organisation (Villeneuve & Gingras, 1998). The questions measuring work climate addressed six dimensions: (a) involvement, (b) consideration, (c) efficacy and fairness of the rules, (d) quality of feedback, (e) autonomy, and (f) recognition/encouragement. The participants were asked to describe the CF by answering 26 items rated across a Likert-type scale ranging from 1 (*do not agree at all*) to 5 (*agree completely*). The alpha value for these combined subscales was .97.

Organisational Commitment

Affective commitment was defined as emotional attachment to the organisation, and continuance commitment as recognition of the costs associated with leaving the organisation. Each subscale of this Affective and Continuance Commitment Scale (Allen & Meyer, 1990) consists of eight Likert-type items with response category ranging from 1 (*do not agree at all*) to 5 (*agree completely*). The internal consistency for the combined affective and continuance components was .66.

Job Satisfaction

The Job Satisfaction Scale (Hackman & Oldham, 1975) is an instrument consisting of 31 items which can be rated along a Likert-type scale ranging from 1 (*do not agree at all*) to 5 (*agree completely*). The dimensions assessed include satisfaction with: (a) nature of the job; (b) salary and benefits; (c) promotion potential and recognition; (d) working conditions; (e) supervision, peers, and the organisation; (f) job security; (g) geographical location of the workplace; and (h) comparative value of the job. The internal consistency was .90 for the combination of these subscales.

Work Strain

Individual ill-being (or strain) was assessed using the 20-item Symptoms Checklist (Bartone, Ursano, Wright, & Ingraham, 1989). This checklist assessed the frequency, using a Likert-type scale ranging from 0 (*never*) to 3 (*very often*), with which symptoms were experienced in four domains: (a) depression/withdrawal, (b) hyperalertness, (c) generalised anxiety, and (d) and somatic complaints. The internal consistency of the total index was .95.

Turnover Intentions

The intent to stay (or leave) an organisation is a predictor of active human behaviour. CF members were asked, using the Retention and Attrition Questionnaire (adapted from Bernard, 2001), to describe their current career aspirations on a Likert-type scale ranging from 1 (*do not agree at all*) to 5 (*agree completely*). The dimensions addressed included: (a) intent to leave the CF/Department of National Defence, (b) intent to pursue a posting out

of the Unit, and (c) intent to stay in the Unit but change job. The internal consistency was .63.

Results

Study 1: Construct Validation

Confirmatory Factor Analysis

CFA was used in Study 1 because it is a powerful approach for evaluating measurement models by allowing researchers to test the hypothesised factor structure of a set of items (Ployhart, 2008). CFA also provides a more stringent test of the underlying factor structure of a survey instrument than any other method, including EFA (Bollen, 1989; Jöreskog & Sörbom, 1989) and multitrait/multimethod approaches (Bagozzi, Yi, & Phillips, 1991). CFA also provides goodness-of-fit indexes for the resulting solution (Anderson & Gerbing, 1988; Kenny & Kasby, 1992). Consequently, CFA was used to determine whether the factorial structure of the WEIMS for this military sample resembled the original five-factor model of work motivation validated by Blais and his colleagues (1993) using a Francophone sample. The integrated regulation construct was also included in the present study. CFA was conducted including all 18 items, with three indicators measuring each type of motivation and was performed on the covariance matrix generated by EQS 6.1 (Bentler, 2005) using the maximum likelihood (ML) estimation method for testing the full six-factor model. Table 1 presents descriptive statistics for each of the 18 work motivation indicators as well as individual item-to-total (for each subscale) correlations.

CFA rendered a satisfactory fit: $\chi^2(120, N = 203) = 185.562$, $p < .001$ (χ^2/df ratio = 1.55; Kline, 1998); Comparative Fit Index (CFI) = .958, standardized root mean square residual (SRMR) = .062, root mean square error of approximation (RMSEA) = .046, 90% confidence interval (CI) RMSEA = .028, .062. Also, all items had standardised factor loadings over .30 (ranging from .30 to .93). Each set of three indicators also showed midrange-to-high item-to-total correlations (all above .50), representing a first indication of construct validity. The final model is depicted in Figure 1.

Internal Consistency

In line with the descriptive statistics presented in Table 2, the results indicated that external regulation ($M = 3.75$) was the main reason why CF members were involved in their work. As well, along the diagonal of Table 2 are presented the Cronbach's alphas assessing the internal consistency of the WEIMS's six subscales. Alpha values ranged from .64 to .83, suggesting adequate reliability (IM = .80; INTEG = .83; IDEN = .67; INTRO = .70; EXT = .77; AMO = .64). Overall, considering the fact that these subscales consist of only three indicators each, they show adequate internal consistency. As well, their respective alpha values are approximately the same as those obtained with the original French scale.⁴

⁴ The alpha values of the original French scale were as follow: IM = .77; IDEN = .75; INTRO = .74; EXT = .73; AMO = .59 (see Blais et al., 1993, for complete details).

Table 1
Means, Standard Deviations, Skewness, and Item-to-Total Correlations for Individual Items of the WEIMS (Study 1)

| Variable | Descriptive statistics | | | |
|------------------------|------------------------|------|--------|-----|
| | M | SD | Skew | r |
| Intrinsic motivation | | | | |
| IM4 | 3.61 | 1.08 | -.415 | .79 |
| IM8 | 3.59 | 1.50 | -.467 | .88 |
| IM15 | 3.57 | 1.59 | -.476 | .86 |
| Integrated regulation | | | | |
| INTEG5 | 3.06 | 1.30 | -.203 | .85 |
| INTEG10 | 3.47 | 1.20 | -.259 | .88 |
| INTEG18 | 3.22 | 1.21 | -.123 | .86 |
| Identified regulation | | | | |
| IDEN1 | 2.91 | 1.27 | -.008 | .73 |
| IDEN7 | 3.05 | 1.28 | -.167 | .80 |
| IDEN14 | 2.98 | 1.08 | -.071 | .80 |
| Introjected regulation | | | | |
| INTRO6 | 3.43 | 1.29 | -0.482 | .79 |
| INTRO11 | 3.41 | 1.22 | -0.466 | .84 |
| INTRO13 | 3.20 | 1.34 | -0.163 | .76 |
| External regulation | | | | |
| EXT2 | 3.68 | 1.13 | -0.519 | .84 |
| EXT9 | 3.80 | 1.24 | -0.716 | .76 |
| EXT16 | 3.76 | 1.14 | -0.482 | .88 |
| Amotivation | | | | |
| AMO3 | 1.52 | .80 | 1.388 | .59 |
| AMO12 | 2.50 | 1.28 | 0.504 | .86 |
| AMO17 | 2.18 | 1.08 | 4.060 | .81 |

Note. $N \leq 205$. Items were rated on a 5-point Likert-type scale ranging from 1 (does not correspond at all) to 5 (corresponds exactly). r s were significant at $p < .01$. WEIMS = Work Extrinsic and Intrinsic Motivation Scale; IM = intrinsic motivation; INTRO = introjected regulation; INTEG = integrated regulation; EXT = external regulation; IDEN = identified regulation; AMO = amotivation.

Content Validity

Pearson correlations computed amongst the six subscales are also presented in Table 2. They were expected to display the presence of a self-determination continuum (Ryan & Connell, 1989). Overall, the quasi-simplex pattern of the present sample is in agreement with the one obtained with the French version of the WEIMS (see Blais et al., 1993). This too provides some preliminary support for the construct validity of this English version. More interesting, introjection yielded a relatively high relationship with integration ($r = .63, p < .01$). As well, external regulation was not significantly related to intrinsic motivation (as was the case in the French validation) and the absence of motivation only yielded significance with integration ($r = -.20, p < .01$).

Study 2: Work Self-Determination Index and Criterion Validity

As an effort to ensure normal distribution patterns for all measured variables, descriptive statistics were first examined and are presented in Table 3 (i.e., work motivation) and Table 4 (i.e., work-related antecedents and consequences). Overall, variables displayed normal distributions. In line with the findings of Study 1, results indicated, here again, external regulation ($M = 3.63$) to be the main underlying motive of CF's membership. For this

sample, the mean value for the W-SDI was equal to + 2.96, indicating a rather low self-determined profile. As well, Cronbach's alphas, further assessing the internal consistency of the six subscales, are presented in Table 3 and were also suggesting fairly good reliability (alphas ranging from .60 to .84).

Work Self-Determination Index

Regression analyses were conducted to examine the relationship between the WEIMS and work-related antecedents and consequences. Results of the linear regression analyses for the W-SDI are presented in Table 4.

As hypothesised, both organisational support ($\beta = .27, p < .001$) and work climate ($\beta = .26, p < .001$) were significantly linked to the W-SDI ($R^2 = .23$). As well, the W-SDI was positively linked to job satisfaction ($\beta = .57, p < .001, R^2 = .33$) and organisational commitment ($\beta = .33, p < .001, R^2 = .11$). It was also negatively linked to work strain ($\beta = -.29, p < .001, R^2 = .08$) and turnover intentions ($\beta = -.48, p < .001, R^2 = .23$). In sum, these findings indicate that a positive work environment is accompanied by higher levels of work self-determination, and that

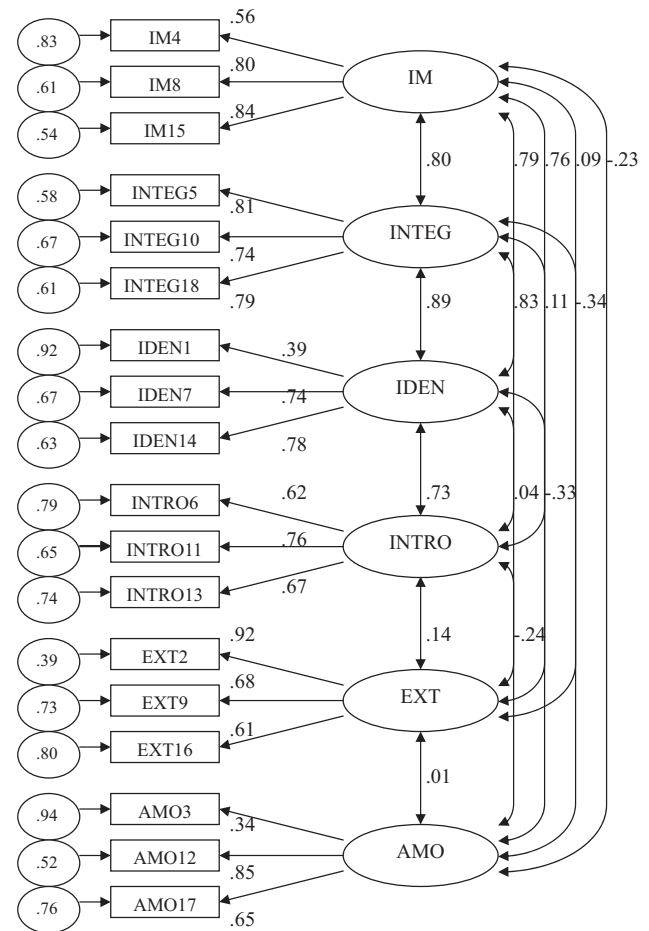

Figure 1. Confirmatory factor analysis of the Work Extrinsic and Intrinsic Motivation Scale (Study 1). IM = intrinsic motivation; INTEG = integrated regulation; IDEN = identified regulation; EXT = external regulation; INTRO = introjected regulation; AMO = amotivation.

Table 2
Means, Standard Deviations, Internal Consistency Values (Cronbach's alpha), and Pearson Correlations for the WEIMS's Subscales (Study 1)

| Variable | Statistics | | WEIMS's subscales | | | | | |
|----------|------------|-----------|-------------------|-------|-------|-------|-------|-------|
| | <i>M</i> | <i>SD</i> | IM | INTEG | IDEN | INTRO | EXT | AMO |
| INTEG | 3.29 | 1.07 | | (.83) | .67 | .63 | .19 | -.20 |
| IDEN | 2.98 | 0.94 | | | (.67) | .49 | .16 | -.12 |
| INTRO | 3.35 | 1.02 | | | | (.70) | .16 | -.13 |
| EXT | 3.75 | 0.99 | | | | | (.77) | .03 |
| AMO | 2.07 | 0.82 | | | | | | (.64) |

Note. $N \leq 205$. All correlations above .16 are significant at $p < .01$. WEIMS = Work Extrinsic and Intrinsic Motivation Scale; IM = intrinsic motivation; INTEG = integrated regulation; IDEN = identified regulation; INTRO = introjected regulation; EXT = external regulation; AMO = amotivation.

the higher the value of one's work self-determination profile, the more engaged in and satisfied with his or her job the individual is likely to be. As well, lower should his or her chances of experiencing work strain and willingness to leave the organisation.

Criterion Validity

Correlations between the WEIMS's subscales and a series of psychological constructs that were considered either motivational antecedents or consequences also appear in Table 4. As hypothesised, perceived organisational support and positive work climate correlated positively with four out of the five types of motivation (r s ranging from .24 to .41, $p < .01$), and correlated negatively with amotivation ($r = -.23$ and $-.25$, $p < .01$, respectively). These two antecedents did not correlate significantly with external regulation.

Job satisfaction and organisational commitment correlated positively with work self-determined types of motivation (r s ranging between .40 and .46 for satisfaction, $p < .01$, and .32 to .41 for commitment) and yielded weaker positive correlations with introjected regulation (r s between .32 to .34, $p < .01$). Whereas external regulation was only positively correlated to commitment ($r = .13$, $p < .05$), amotivation yielded negative

correlations with both constructs ($r = -.13$ and $-.34$, $ps < .05$). Also, work strain was positively correlated to amotivation ($r = .33$, $p < .01$), yielding no significant correlations with the other five variables. Finally, with the exception of external regulation, significant negative correlations were found between turnover intentions and all of the types of work motivation (i.e., self-determined: r s between $-.35$ to $-.47$, $ps < .01$; nonself-determined: r s between $-.20$ and $-.26$, $p < .01$). These results further demonstrate how each form of motivation relates differently to work-related criteria.

Study 3

Study 3 further examined the criterion related validity of the WEIMS for predicting various organisational criteria. This was done by presenting the second of two ways of using the WEIMS for prediction purposes, namely the use of the two forms of work motivation (i.e., work self-determined motivation (W-SDM) versus nonself-determined motivation (W-NSDM)). Whereas W-SDM was hypothesised to be linked to positive consequences, mainly organisational involvement, commitment and citizenship behaviours, W-NSDM was hypothesised to be less so linked to those variables as well as to be positively

Table 3
Means, Standard Deviations, Variance, Skewness, and Alpha Values for the WEIMS's Subscales and the W-SDI (Study 2)

| Variable | Descriptive statistics | | | | |
|-----------------|------------------------|-----------|----------|----------|----------|
| | <i>M</i> | <i>SD</i> | Variance | Skewness | α |
| WEIMS subscales | | | | | |
| IM | 3.49 | 0.96 | .91 | -.48 | .77 |
| INTEG | 3.18 | 1.11 | 1.23 | -.32 | .84 |
| IDEN | 2.92 | 1.01 | 1.01 | .02 | .74 |
| INTRO | 3.12 | 1.07 | 1.14 | -.18 | .71 |
| EXT | 3.63 | 1.07 | 1.13 | -.53 | .81 |
| AMO | 2.14 | 0.85 | 0.73 | .53 | .60 |
| W-SDI | 2.96 | 5.39 | 29.03 | -.09 | .84 |

Note. $N \leq 260$. Items were rated on a 5-point Likert-type scale ranging from 1 (does not correspond at all) to 5 (corresponds exactly). WEIMS = Work Extrinsic and Intrinsic Motivation Scale; W-SDI = Work Self-Determination Index; IM = intrinsic motivation; INTEG = integrated regulation; IDEN = identified regulation; INTRO = introjected regulation; EXT = external regulation; AMO = amotivation.

Table 4
Correlations Between WEIMS Subscales and Motivational Antecedents and Consequences as Well as β and Adjusted R^2 From W-SDI Regression Analyses (Study 2)

| Variable | Antecedents | | Consequences | | | |
|-------------------------------|-------------|---------|--------------|---------|--------|----------|
| | Support | Climate | Job Sat. | Commit. | Strain | Turnover |
| <i>M</i> | 2.60 | 2.74 | 2.84 | 2.93 | 21.58 | 2.58 |
| <i>SD</i> | 0.73 | 0.93 | 0.65 | 0.61 | 16.32 | 0.98 |
| α | .90 | .97 | .89 | .67 | .95 | .65 |
| WEIMS subscales | | | | | | |
| IM | .34 | .41 | .46 | .41 | -.06 | -.47 |
| INTEG | .34 | .37 | .45 | .37 | -.12 | -.36 |
| IDEN | .26 | .34 | .40 | .32 | -.08 | -.35 |
| INTRO | .24 | .34 | .34 | .32 | -.01 | -.26 |
| EXT | -.04 | .07 | .02 | .13 | .10 | -.03 |
| AMO | -.23 | -.25 | -.34 | -.13 | .33 | .20 |
| Work Self-Determination Index | | | | | | |
| W-SDI | .27 | .26 | .57 | .33 | -.29 | -.48 |
| R^2 | .23 | | .33 | .11 | .08 | .23 |

Note. $N \leq 260$. All correlations above .13 are significant at $p < .05$. WEIMS = Work Extrinsic and Intrinsic Motivation Scale; IM = intrinsic motivation; INTEG = integrated regulation; IDEN = identified regulation; INTRO = introjected regulation; EXT = external regulation; AMO = amotivation; W-SDI = Work Self-Determination Index; Job Sat. = job satisfaction; Commit. = commitment.

linked to more negative ones that is workplace deviant behaviours. In terms of scale validation, Study 3 also evaluated the factorial invariance of the WEIMS across samples (i.e., Study 1 and 2: military vs. Study 3: civilian). It was hypothesised that the WEIMS's set of 18 indicators would assess the same six latent constructs (i.e., types of motivation) in both samples.

Method

Participants and Procedure

A sample of 192 workers from diverse organisations in the Ottawa-Gatineau region completed a questionnaire during their free time and returned it to the researchers by mail. Return envelopes and postage were provided. Participation in the study was voluntary, and participants were informed that their responses would be anonymous and kept confidential. A total of 112 women and 76 men completed the questionnaire (4 individuals did not indicate their gender). The mean age of participants was 35.79. The majority of the sample was federal government employees (45.3%; national organisation: 33.3%; multinational organisation: 28.6%), whereas the others worked either in the service industry (28.2%) and/or sale/retail (19.3%; small office: 34.4%). Participants earned an average salary between \$40,001 and \$60,000 per annum (university degree: 46.5%; collegial certificate: 28.1%; high school diploma: 22.5%).

Measures

Work Motivation (See Study 1 for Complete Details)

Participants were asked to indicate their level of agreement with each of the 18 items, using a Likert-type scale ranging from 1 (*does not correspond at all*) to 7 (*corresponds exactly*). In addition to the W-SDI (described in the Method section of Study 2), the

WEIMS was used to examine the influence of work self-determined as opposed to nonself-determined motivation. A score for W-SDM can be generated by summing the means of each of the three self-determined subscales (i.e., IM, INTEG, and IDEN). Similarly, a score for W-NSDM can be obtained by summing the means of the three nonself-determined subscales (i.e., INTRO, EXT, and AMO). Either for prediction purposes or when testing comprehensive theoretical models with techniques such as structural equation modelling, these two forms of work motivation are useful when researchers need to reduce the number of indicators (i.e., latent variables) to provide adequate tests of models. Internal consistency values of .87 and .72 were obtained for work self-determined and nonself-determined motivation, respectively.

Organisational Involvement

Involvement was measured through the use of a 12-item scale, developed by Tyler and Blader (2002). Participants indicated their agreement on a Likert-type scale ranging from 1 (*strongly disagree*) to 6 (*strongly agree*). Internal consistency tests revealed an alpha value of .85.

Organisational Commitment

Participants completed an aggregated 18-item measure of commitment by indicating their agreement with each item on a Likert-type scale ranging from 1 (*never*) to 7 (*always*). Five of the 18 items measured general organisational commitment (Meyer & Allen, 1991), 7 tapped team-oriented commitment, and 6 measured career-oriented commitment (Ellemers, de Gilder, & van den Heuvel, 1998). The alpha coefficient for the combined subscales was .90.

Organisational Citizenship Behaviours

Organisational citizenship behaviours were assessed using a 13-item measure of working with others (Podsakoff, Ahearne,

& MacKenzie, 1997). Participants indicated their agreement on a Likert-type scale ranging from 1 (*never*) to 7 (*always*). The alpha value for this measure was .90.

Workplace Deviant Behaviours

Participants completed the Workplace Deviance Scale (Bennett & Robinson, 2000) which is comprised of two subscales: a 13-item measure of organisational deviance (deviant behaviours directly harmful to the organisation), and a 7-item measure of interpersonal deviance (deviant behaviours directly harmful to other individuals within the organisation). Participants indicated the frequency to which each behaviour was representative of their own on a Likert-type scale ranging from 1 (*never*) to 7 (*always*). An alpha value of .84 was obtained.

Results

Descriptive statistics were examined to assess normal distribution patterns for all measured variables. They are presented in Table 5. Means of 4.35 and 3.73 were obtained for work self-determined and nonself-determined motivation, respectively. Overall, the variables followed normal distributions. In addition, similar alpha values to the ones obtained for the CF sample, were obtained for the subscales using this civilian sample (IM = .87; INTEG = .80; IDEN = .70; INTRO = .76; EXT = .73; AMO = .75).

To the exception of the absence of a correlation between work nonself-determined motivation, organisational involvement and commitment, hypotheses were generally supported. Moreover, the two forms of motivation (i.e., W-SDM and W-NSDM) were positively correlated ($r = .31, p < .01$). Significant correlations (r s ranging from .20 to .66, p s < .01) were also found between all measured outcome variables (i.e., involvement, commitment, citizenship, and deviance), to the exception of the link between deviant behaviours and both organisational involvement and commitment.

Work Self-Determined and Nonself-Determined Motivation

Regression analyses were conducted to demonstrate the usefulness of the WEIMS in predicting positive as well as negative organisational consequences, depending on one's work self-determined and nonself-determined motivation.⁵ As expected, W-SDM was positively linked to organisational involvement ($\beta = .49, p < .001$), commitment ($\beta = .54, p < .001$), and citizenship behaviours ($\beta = .44, p < .001$) as well negatively linked to deviant behaviours ($\beta = -.24, p < .001$); the individual more likely acting (and reacting) positively toward the organisation and his or her fellow coworkers. W-NSDM was found to be negatively linked to citizenship behaviours ($\beta = -.29, p < .001$) and positively linked to deviant behaviours ($\beta = .25, p < .001$); the individual more likely engaging in antisocial or organisational behaviours. No significant relationships were found between W-NSDM, involvement and commitment. Taken together, W-SDM and W-NSDM explained 23% of the variance in organisational involvement, 27% of work commitment, 19% of citizenship behaviours, and 7% of workplace deviance. Results of the regression analyses for the two

forms of work motivation (i.e., W-SDM and W-NSDM) are presented in Table 6.

Factorial Invariance

Although the WEIMS was identically specified for both military and civilian samples, this does not guarantee the equivalence of item measurements across the two groups (Kline, 1998). For example, despite an identically specified factor loading, it is possible that with the imposition of equality constraints across groups, the tenability of invariance would not hold. That is, the link between a particular indicator and its target latent construct may be sample specific (Byrne, 1994). Prior to the evaluation of the WEIMS's factorial invariance (i.e., military: Study 1 and 2, $N = 205$, civilians: Study 3, $N = 192$), scores from the 18 items were first converted into z scores to render a more adequate invariance assessment. This procedure was used because work motivation was assessed by the WEIMS using two different Likert-type scales (i.e., Study 1 and 2: 5 point; Study 3: 7 point).

Results for this test of the measurement model using structural equation modelling yielded a satisfactory CFI value of .902, $\chi^2(273, N = 395) = 540.315, p < .001, \chi^2/df$ ratio = 1.98, SRMR = .095, RMSEA = .052, 90% CI RMSEA = .045, .058. This suggests that the hypothesised model invariance represents an acceptable fit to the data. More important, an examination of probability values associated with the LM univariate and multivariate chi-square test statistics revealed none of the WEIMS's 18 items to be invariant across groups.

General Discussion

The purpose of the present research was to assess the applicability of the WEIMS by testing its factorial structure and its psychometric properties using different work environments. Three studies were conducted.

A series of regression analyses revealed that the WEIMS has construct, content, and criterion validity for organisational settings. Replicating the correlational findings of previous studies, the present results support the use of the work self-determination index (Study 2) and are consistent with SDT's assertion that as self-determination rises, consequences become increasingly positive (e.g., job satisfaction and commitment), whereas lower levels of self-determination result in more negative experiences (e.g., work strain, turnover intentions).

The present results also support the WEIMS's ability to predict positive and negative organisational criteria based on one's work self-determined motivation and work nonself-determined motivation (Study 3). As hypothesised, as self-determined motivation

⁵ The factor analytic support for the claim that the WEIMS can be conceptualized as two forms of motivation, namely W-SDM and W-NSDM was first tested by the mean of a second-order CFA (Byrne, 1994). In this second-order CFA, the six motivation types were hypothesized to be explained by two second-order factors: W-SDM (comprised of IM, INTEG, IDEN) and W-NSDM (comprised of INTRO, EXT, AMO). Results yielded a CFI value of .919, $\chi^2(130, N = 192) = 393.323, p < .001, \chi^2/df$ ratio = 3.03, SRMR = .081, RMSEA = .116, 90% CI RMSEA = .072, .163; indicating that the hypothesized binary higher order motivational structure represents an acceptable fit to the data.

Table 5
Descriptive Statistics and Correlations (Cronbach's alpha) Between the Two Forms of Work Motivation and Related Consequences (Study 3)

| Variable | Statistics | | Motivation | | Consequences | | | |
|----------------|------------|-----------|------------|-------|--------------|-------|-------|-------|
| | <i>M</i> | <i>SD</i> | 1 | 2 | 3 | 4 | 5 | 6 |
| Motivation | | | | | | | | |
| 1. W-SDM | 4.35 | 1.18 | (.87) | .31 | .49 | .53 | .35 | -.16 |
| 2. W-NSDM | 3.73 | .92 | | (.72) | .13 | .12 | -.16 | .18 |
| Consequences | | | | | | | | |
| 3. Involvement | 4.27 | .82 | | | (.85) | .66 | .38 | -.12 |
| 4. Commitment | 4.43 | .90 | | | | (.90) | .45 | -.07 |
| 5. Citizenship | 5.12 | .93 | | | | | (.90) | -.27 |
| 6. Deviance | 1.69 | .53 | | | | | | (.84) |

Note. $N \leq 192$. $r_s \geq .16$ are significant at $p < .05$. W-SDM = Work Self-Determined Motivation; W-NSDM = Work Nonself-Determined Motivation.

increases, individuals are more likely to report being involved in and committed to their work as well as connected and loyal to the organisation. In contrast, higher levels of work nonself-determined motivation resulted in employees being less inclined to help coworkers and being more likely to engage in deviant behaviours.

More interesting, these findings also suggest that work nonself-determined motivation may be more specifically associated with consequences involving others (i.e., citizenship and interpersonal deviant behaviours), rather than those usually originating from the self (i.e., organisational involvement and commitment). In a similar vein, previous research revealed that low levels of self-determination may create a "passive set" such that individuals are more likely to do the minimum amount of work required to obtain desired rewards or avoid punishments (Pelletier et al., 1995). The end result may be a corresponding lack of citizenship behaviour (e.g., "always find fault with what other crew members are doing," "discouraging each other when someone is down"), and an increase in deviant behaviours (e.g., "acting rudely toward someone, making an ethnic, religious or racial remark").

Together with the W-SDI, these are the two different ways of computing the six types of motivation assessed with the WEIMS. Researchers, as well as practitioners, may use either index depending on their objectives. However, one may argue that the use of only one index (i.e., W-SDI and W-SDM vs. W-NSDM) may lead to incomplete information. For example, they may fail to

indicate which particular type of motivation (e.g., IM vs. INTRO vs. AMO) is the best indicator of various consequences. Furthermore, they may fail to identify changes occurring over time with respect to the impact of the different types of motivation on different criteria. For that reason, work motivation should still be viewed as a multidimensional concept, with six different types of motivation lying along a self-determination continuum (Deci & Ryan, 1985). In fact, SDT's original view of motivation was supported by the present results with different types of motivation being associated with a wide range of criteria (both positive and negative; see Table 4).

Results pertaining to the validation of the WEIMS are also consistent with the findings obtained with similar SDT-based instruments used in other life domains (e.g., sports: Pelletier et al., 1995; environment: Pelletier, Tuson, Green-Demers, Noels & Beaton, 1998). This enables a high degree of consistency in estimates of factor loadings, reliability, and intercorrelations as well as content and criterion validity. In addition, the WEIMS's factorial structure was tested via a multisamples analysis by means of structural equation modelling. The proposed pattern of relationships was found significant in and invariant across, both military and civilian samples. This finding of invariance suggests that the factorial structure of the WEIMS seems rather stable within these two distinct occupational groups. This further suggests that the WEIMS can be used across different populations of workers with minimum concern for sample specificity.

Table 6
Standardized Parameter Estimates (β) and Adjusted R^2 Values for Each Prediction Based on the Two Work Motivational Forms (Study 3)

| Variable | Motivation | | | Consequences | | |
|------------------|------------|-----------|-------------|--------------|-------------|----------|
| | W-SDM | W-NSDM | Involvement | Commitment | Citizenship | Deviance |
| Motivation forms | | | | | | |
| W-SDM | — | — | .49 | .54 | .44 | -.24 |
| W-NSDM | — | — | <i>ns</i> | <i>ns</i> | -.29 | .25 |
| R^2 | .17 | <i>ns</i> | .23 | .27 | .19 | .07 |

Note. $N \leq 192$. All parameter estimates are significant at $p \leq .001$. W-SDM = Work Self-Determined Motivation; W-NSDM = Work Nonself-Determined Motivation; *ns* = not significant.

Nonetheless, some results pertaining to the quasi-simplex pattern of relationships for Study 1 yielded unexpected results. Introjection was highly associated with one type of self-determined motivation, namely integration. Regarding this, a posteriori descriptive statistics revealed that CF members displayed higher levels of introjection than their civilian counterparts. Also, a posteriori Pearson correlations were performed on the WEIMS's subscales of Study 3. Results revealed that the pattern of relationships was similar to the one displayed in the original French validation. That is, in the civilian sample, introjection was less strongly associated with integration than in the military sample. It was more strongly related to the other two nonself-determined types of motivation, namely external regulation and amotivation. This may reflect different employment conditions and/or a byproduct of the organisational culture (e.g., Masi & Cooke, 2000; Trice & Beyer, 1993; Wilkins, 1989).

Future Research

Future research should investigate how personal characteristics may lead to different motivational orientations. Sheldon and Elliot (1998) pointed out that because self-determined goals originate from personal values, and because they are viewed as the mechanism by which values transfer into action (Latham & Pinder, 2005), they arguably have an advantage over those that are externally forced (Deci & Ryan, 1991). Thusly they are likely to garner the highest levels of effort and persistence.

During the last two decades, there has also been a shift in organisations toward more group-based workforce (Ambrose & Kulik, 1999). As they continue to move toward larger group-based systems, research on work motivation is increasingly important and should focus on its applicability to teams and team effectiveness (e.g., Ellemers, de Gilder, & Haslam, 2004; Erez, Kleinbeck, & Thierry, 2001). That is, there may be substantial processes affecting teams that do not arise when the focus is on the individual (e.g., ways in which team members motivate and demotivate one another; Locke & Latham, 2004).

Another topic for future research is the pattern of interrelationships between the work outcome variables. Consequently, if the goal is to understand employees' behaviours, as well as predicting them, one also cannot neglect measuring important mediating (and potentially moderating) variables capturing the essence of such phenomenon (Latham & Pinder, 2005).

As a last remark, research is needed to not only measure work-related criteria via self-reports, but in addition to examine the usefulness of the WEIMS in predicting actual behaviours, based on previous evaluation of employee motivational orientation, whether at the uni-, binary-, or multidimensional level of analysis. Given that work motivation is a significant determinant of activity persistence (Deci & Ryan, 1985), self-determined forms of work motivation may be positively associated with work perseverance (and negatively with voluntary turnover). Researchers ought to use multiple methods, for instance self-reports, observation techniques, and/or objective criteria.

Limitations

The limitations of the present research include the use of self-reports and a cross-sectional design. Regarding the use of self-

reports, common-method variance may have occurred, leading to spurious relationships between work motivation and its correlates. A related limitation is the use of self-reports is the issue of social desirability. For instance, individuals may have underreported deviant behaviours because they did not want to admit to having engaged in such socially undesirable actions. This type of measurement error may partially account for the low means and high skewness obtained in this research with regard to the measurement of amotivation, workplace deviance, and turnover intentions. Progress in this domain could be reached by juxtaposing implicit measures of work motivation to subjective ones (such as the WEIMS) to predict actual behaviours. It is believed that the valid measurement of conscious work motives, using the WEIMS, represents a critical first step toward this goal. As a result of using multiple techniques, different samples, and a variety of work settings, the issue of generalisability could also be somewhat resolved. Finally, given the cross-sectional nature of the present research, arguments cannot be made that a particular form (or type) of motivation was causal with respect to specific work-related criteria.

Conclusions

Although results of the present research provide support for the applicability and validity of the WEIMS, additional studies will be necessary to further establish the psychometric properties of the scale. Notwithstanding the aforementioned limitations, the current research presents the WEIMS as a reliable and valid work motivation instrument in its own right, assessing six theoretically driven motivational tendencies and offering multiple indexes, which are worth using in future research within the field of organisational psychology, more specifically on research pertaining to work motivation.

It is our hope that the use of the WEIMS will contribute to a better comprehension of the interaction between work characteristics, employee motivation, and organisational functioning. That is, the WEIMS should be viewed a useful tool in identifying how general variables such as motivational profiles get applied to, and are mediated by, task- and situationally specific variables, and how they affect individual choices and overall organisation structuring.

Résumé

L'échelle de motivation intrinsèque et extrinsèque au travail (EMIET) est une mesure à 18 items de la motivation au travail ayant pour fondation théorique la théorie d'autodétermination (Deci & Ryan, 2000). La présente recherche s'organisaient avait deux objectifs. Premièrement, l'applicabilité de l'EMIET a été testée dans différents milieux de travail. Deuxièmement, sa structure ainsi que ses propriétés psychométriques ont été mesurées. Deux échantillons de travailleurs (militaires : $N = 465$; civils : $N = 192$) volontaires ont rempli les questionnaires. En utilisant les indexes de l'EMIET 3 (respectivement, l'index d'autodétermination au travail, de motivation au travail autodéterminée et non autodéterminée), les résultats des analyses de régression ont appuyé sa capacité prédictive de critères positifs et négatifs au travail. Les résultats ont aussi montré l'adéquation de sa validité de construit et de sa consistance interne. Sa structure factorielle était aussi constante à travers les groupes. Finalement,

son patron quasi-simplex et ses relations avec des corrélats psychologiques sont davantage venus appuyer le continuum d'autodétermination. En somme, ces résultats fournissent des appuis pour l'applicabilité, la fidélité et la validité de l'EMMET en milieu de travail.

Mots-clés : motivation au travail, théorie d'autodétermination, validation d'échelle

References

- Allen, N. J., & Meyer, J. P. (1990). The measurement and antecedents of affective, continuance, and normative commitment to the organization. *Journal of Occupational and Organizational Psychology*, 63, 1–18.
- Ambrose, M. L., & Kulik, C. T. (1999). Old friends, new faces: Motivation research in the 1990s. *Journal of Management*, 25, 231–292.
- Anderson, J., & Gerbing, D. W. (1988). Structural equations modeling in practice: A review and recommended two-step approach. *Psychological Bulletin*, 103, 411–423.
- Baard, P. P., Deci, E. L., & Ryan, R. M. (2004). The relation of intrinsic need satisfaction to performance and well-being in two work settings. *Journal of Applied Social Psychology*, 34, 2045–2068.
- Bagozzi, R. P., Yi, Y., & Phillips, L. W. (1991). Assessing construct validity in organizational research. *Administrative Science Quarterly*, 36, 421–458.
- Baron, R. A. (1991). Motivation in work settings: Reflections on the core of organizational research. *Motivation and Emotion*, 15, 1–8.
- Bartone, P. T., Ursano, R. J., Wright, K. M., & Ingraham, L. H. (1989). The impact of a military air disaster on the health of assistance workers: A prospective study. *Journal of Nervous and Mental Disease*, 177, 317–327.
- Bennett, R. J., & Robinson, S. L. (2000). Development of a Measure of Workplace Deviance. *Journal of Applied Psychology*, 85, 349–360.
- Bentler, P. M. (2005). *EQS 6.1 for Windows*. Multivariate Software.
- Bernard, J. (2001). *Les facteurs explicatifs de la rétention du personnel d'officiers au sein du Commandement Aérien des Forces Canadiennes*. Ottawa : Defence Research and Development Canada.
- Blais, M. R., Lachance, L., Vallerand, R. J., Brière, N. M., & Riddle, A. S. (1993). The Blais Inventory of Work Motivation [French]. *Revue Québécoise de Psychologie*, 14, 185–215.
- Blanton, H., & Jaccard, J. (2006). Arbitrary metrics in psychology. *American Psychologist*, 61, 27–41.
- Bollen, K. A. (1989). *Structural equations with latent variables*. New York: Wiley.
- Byrne, B. M. (1994). *Structural equation modeling with EQS and EQS/Windows: Basic concepts, applications, and programming*. London: Sage.
- Deci, E. L., Connell, J. P., & Ryan, R. M. (1989). Self-determination in a work organization. *Journal of Applied Psychology*, 74, 580–590.
- Deci, E. L., & Ryan, R. M. (1985). *Intrinsic motivation and self-determination in human behavior*. New York: Plenum.
- Deci, E. L., & Ryan, R. M. (1991). A motivational approach to integration of self: Integration in personality. In R. Dienstbier (Ed.), *Nebraska Symposium on Motivation: Perspectives on motivation* (pp. 237–288). Lincoln: University of Nebraska Press.
- Deci, E. L., & Ryan, R. M. (2000). The “what” and “why” of goal pursuits: Human needs and the self-determination of behavior. *Psychological Inquiry*, 11, 227–268.
- Deci, E. L., & Ryan, R. M. (2002). *Handbook of self-determination research*. Rochester, NY: University of Rochester Press.
- Eisenberg, R., Huntington, R., Hutchison, S., & Sowa, D. (1986). Perceived organizational support. *Journal of Applied Psychology*, 71, 200–207.
- Ellemers, N., de Gilder, D., & Haslam, S. A. (2004). Motivating individuals and groups at work: A social identity perspective on leadership and group performance. *Academy of Management Review*, 29, 459–478.
- Ellemers, N., de Gilder, D., & van den Heuvel, H. (1998). Career-oriented versus team-oriented commitment and behavior at work. *Journal of Applied Psychology*, 83, 717–730.
- Erez, M., Kleinbeck, U., & Thierry, H. (2001). *Work motivation in the context of a globalizing economy*. Mahwah, NJ: Erlbaum.
- Fortier, M. S., Vallerand, R. J., & Guay, F. (1995). Academic motivation and school performance: Toward a structural model. *Contemporary Educational Psychology*, 20, 257–274.
- Gagné, M. (2003). The role of autonomy support and autonomy orientation in the engagement of prosocial behavior. *Motivation and Emotion*, 27, 199–223.
- Gagné, M., & Deci, E. L. (2005). Self-determination theory and work motivation. *Journal of Organizational Behavior*, 26, 331–362.
- Gagné, M., & Forest, J. (2008). The study of compensation systems through the lens of self-determination theory: Reconciling 35 years of debate. *Canadian Psychology*, 49, 225–232.
- Green-Demers, I., Pelletier, L. G., & Ménard, S. (1997). The impact of behavioural difficulty on the saliency of the association between self-determined motivation and environmental behaviours. *Canadian Journal of Behavioural Science*, 29, 157–166.
- Greenwald, A. G., & Banaji, M. R. (1995). Implicit social cognition: Attitudes, self-esteem, and stereotypes. *Psychological Review*, 102, 4–27.
- Guay, F., Blais, M. R., Vallerand, R. J., & Pelletier, L. G. (1999). *The Global Motivation Scale*. Unpublished manuscript, Université du Québec à Montréal.
- Hackman, J. R., & Oldham, G. R. (1975). Development of the Job Diagnostic Survey. *Journal of Applied Psychology*, 60, 159–170.
- Houkes, I., Janssen, P. P. M., de Jonge, J., & Nijhuis, F. J. N. (2001). Specific relationships between work characteristics and intrinsic work motivation, burnout and turnover intentions: A multi-sample analysis. *European Journal of Work and Organizational Psychology*, 10, 1–23.
- Houkes, I., Janssen, P. P. M., de Jonge, J., & Bakker, A. B. (2003). Specific determinants of intrinsic work motivation, emotional exhaustion and turnover intention: A multisample longitudinal study. *Journal of Occupational and Organizational Psychology*, 76, 427–450.
- James, L. R., & Mazerolle, M. D. (2002). *Personality in work organizations: An integrative approach*. Beverly Hills, CA: Sage.
- Johnson, R. E., & Steinman, L. (2009). Use of implicit measures for organisational research: An empirical example. *Canadian Journal of Behavioural Science*, 41, 202–212.
- Jöreskog, K. G., & Sörbom, D. (1989). *LISREL 7: User's reference guide*. Lincolnwood, IL: Scientific Software International.
- Kanfer, R., Chen, G., & Pritchard, R. D. (2008). Work motivation: Forging new perspectives and directions in the post-millennium. In R. Kanfer, G. Chen, & R. D. Pritchard (Eds.), *Work motivation: Past, present, and future* (pp. 601–631). New York: Taylor & Francis.
- Kanfer, R., & Heggestad, E. D. (1997). Motivational traits and skills: A person-centered approach to work motivation. *Research in Organizational Behavior*, 19, 1–56.
- Kehr, H. M. (2004). Integrating implicit motives, explicit motives, and perceived abilities: The compensatory model of work motivation and volition. *Academy of Management Review*, 29, 479–499.
- Kenny, D. A., & Kasby, D. A. (1992). Analysis of multi trait–multi method matrix by confirmatory factor analysis. *Psychological Bulletin*, 112, 165–172.
- Kline, R. B. (1998). *Principles and practice of structural equation modeling*. New York: Guilford.
- Landy, F. J., & Guion, R. M. (1970). Development of scales for the measurement of work motivation. *Organizational Behavior and Human Performance*, 5, 93–103.
- Latham, G. P., & Pinder, C. C. (2005). Work motivation theory and

- research at the dawn of the twenty-first century. *Annual Review of Psychology*, 56, 485–516.
- Locke, E. A., & Latham, G. P. (2004). What should we do about motivation theory? Six recommendations for the twenty-first century. *Academy of Management Review*, 28, 388–403.
- Masi, R. J., & Cooke, R. A. (2000). Effects of transformational leadership on subordinate motivation, empowering norms, and organizational productivity. *International Journal of Organizational Analysis*, 8, 16–47.
- Meyer, J. P., & Allen, N. J. (1991). A three-component conceptualization of organizational commitment. *Human Resource Management Review*, 1, 61–89.
- Meyer, J. P., Becker, T. E., & Vandenberghe, C. (2004). Employee commitment and motivation: A conceptual analysis and integrative model. *Journal of Applied Psychology*, 89, 91–1007.
- Meyer, J. P., & Gagné, M. (2008). Employee engagement from a self-determination theory perspective. *Industrial and Organizational Psychology*, 1, 60–62.
- Miner, J. B. (2002). The role motivation theories of organizational leadership. In F. J. Yammarino & B. J. Avolio (Eds.), *Transformational and charismatic leadership: The road ahead*. New York: Elsevier.
- Murray, H. A. (1943). *Thematic Apperception Test manual*. Cambridge, MA: Harvard University Press.
- Pelletier, L. G., Dion, S. C., Slovinec-D'Angelo, M., & Reid, R. (2004). Why do you regulate what you eat? Relationship between forms of regulation, eating behaviors, sustained dietary behavior change, and psychological adjustment. *Motivation and Emotion*, 28, 245–277.
- Pelletier, L. G., Tuson, K. M., Fortier, M. S., Vallerand, R. J., Brière, N. M., & Blais, M. R. (1995). Toward a new measure of intrinsic motivation, extrinsic motivation, and amotivation in sports: The Sport Motivation Scale (SMS). *Journal of Sports and Exercise Psychology*, 17, 35–53.
- Pelletier, L. G., Tuson, K. M., Green-Demers, I., Noels, K., & Beaton, A. M. (1998). Why are you doing things for the environment? The Motivation Towards the Environment Scale (MTES). *Journal of Applied Social Psychology*, 28, 437–468.
- Pelletier, L. G., Vallerand, R. J., Blais, M. R., Brière, N. M., & Green-Demers, I. (1996). Construction and validation of the Leisure Motivation Scale [French]. *Loisir et Société*, 19, 559–585.
- Pinder, C. C. (1998). *Work motivation in organizational behavior*. Upper Saddle River, NJ: Prentice Hall.
- Ployhart, R. E. (2008). The measurement and analysis of motivation. In R. Kanfer, G. Chen, & R. D. Pritchard (Eds.), *Work motivation: Past, present, and future* (pp. 17–61). New York: Taylor & Francis.
- Ployhart, R. E., Schneider, B., & Schmitt, N. (2006). *Staffing organizations: Contemporary practice and theory*. Mahwah, NJ: Erlbaum.
- Podsakoff, P. M., Ahearne, M., & MacKenzie, S. B. (1997). Organizational citizenship behavior and the quantity and quality of work group performance. *Journal of Applied Psychology*, 82, 262–270.
- Quast, H.-H., & Kleinbeck, U. (1990). Motivational determinants of absence behavior. In U. Kleinbeck, H.-H. Quast, H. Thierry, & H. Häcker (Eds.), *Work motivation* (pp. 157–167). Hillsdale, NJ: Erlbaum.
- Roth, P. L., Huffcutt, A. I., & Bobko, P. (2003). Ethnic group differences in measures of job performance: A new meta-analysis. *Journal of Applied Psychology*, 88, 694–706.
- Ryan, R. M. (1995). Psychological needs and the facilitation of integrative processes. *Journal of Personality*, 63, 397–427.
- Ryan, R. M., & Connell, J. P. (1989). Perceived locus of causality and internalization. *Journal of Personality and Social Psychology*, 57, 749–761.
- Ryan, R. M., & Deci, E. L. (2000). Self-determination theory and the facilitation of intrinsic motivation, social development, and well-being. *American Psychologist*, 55, 68–78.
- Ryan, R. M., & Deci, E. L. (2002). Overview of self-determination theory: An organismic dialectical perspective. In E. L. Deci, & R. M. Ryan (Eds.), *Handbook of self-determination research* (pp. 3–33). Rochester, NY: University of Rochester Press.
- Sheldon, K. M., & Elliot, A. J. (1998). Not all personal goals are personal: Comparing autonomous and controlled reasons for goals as predictors of effect and attainment. *Personality and Social Psychology Bulletin*, 24, 546–557.
- Steers, R. M., Mowday, R. T., & Shapiro, D. L. (2004). The future of work motivation theory. *Academy of Management Review*, 29, 379–387.
- Tabachnick, B. G., & Fidell, L. S. (2001). *Using multivariate statistics*. Boston: Allyn & Bacon.
- Thierry, H. (1990). Intrinsic motivation reconsidered. In U. Kleinbeck, H.-H. Quast, H. Thierry, & H. Häcker (Eds.), *Work motivation: Series in applied psychology* (pp. 67–82). Hillsdale, NJ: Erlbaum.
- Trice, H. M., & Beyer, J. M. (1993). *The culture of work organizations*. Englewood Cliffs, NJ: Prentice Hall.
- Tyler, T. R., & Blader, S. L. (2002). Terms of engagement: Why do people invest themselves in work? *Research on Managing Group and Teams*, 4, 115–140.
- Vallerand, R. J. (1989). Toward a methodology for the transcultural validation of psychological questionnaires: Implications for research in the French language [French]. *Canadian Psychology*, 30, 662–680.
- Vallerand, R. J. (1997). Toward a hierarchical model of intrinsic and extrinsic motivation. In M. P. Zanna (Ed.), *Advances in experimental social psychology* (pp. 271–360). San Diego, CA: Academic.
- Vallerand, R. J., Blais, M. R., Brière, N. M., & Pelletier, L. G. (1989). On the construction and validation of the French form of the Academic Motivation Scale [French]. *Canadian Journal of Behavioral Science*, 21, 323–349.
- Vallerand, R. J., & Ratelle, C. F. (2002). Intrinsic and extrinsic motivation: A hierarchical model. In E. L. Deci & R. M. Ryan (Eds.), *Handbook of self-determination research* (pp. 3–33). Rochester, NY: University of Rochester Press.
- Villeneuve, M., & Gingras, C. (1998). *Report of the study of officer cadets' perception of the organizational climate at the Royal Military College of Canada*. Kingston, Ontario: Defence Research and Development Canada.
- Warr, P. B., Cook, J., & Wall, T. D. (1979). Scales for the measurement of some work attitudes and aspects of psychological well-being. *Journal of Occupational and Organizational Psychology*, 52, 129–148.
- Weege, J., Van Dick, R., Fisher, G. K., Wecking, C., & Moltzen, K. (2006). Work motivation, organizational identification and well-being in call centre work. *Work and Stress*, 20, 60–83.
- Wilkins, A. L. (1989). *Developing corporate character: How to successfully change an organization without destroying it*. San Francisco: Jossey-Bass.
- Zuckerman, M., Porac, J., Lathin, D., Smith, R., & Deci, E. L. (1978). On the importance of self-determination for intrinsically motivated behavior. *Personality and Social Psychology Bulletin*, 4, 443–446.

(Appendix follows)

Appendix A

Why Do You Do Your Work?

Using the scale below, please indicate to what extent each of the following items corresponds to the reasons why you are presently involved in your work

| Does not correspond at all | Corresponds moderately | | | | | Corresponds exactly | | | | |
|--|------------------------|---|---|---|---|---------------------|---|---|---|---|
| | 1 | 2 | 3 | 4 | 5 | 6 | 7 | | | |
| 1. Because this is the type of work I chose to do to attain a certain lifestyle. | | | | 1 | 2 | 3 | 4 | 5 | 6 | 7 |
| 2. For the income it provides me. | | | | 1 | 2 | 3 | 4 | 5 | 6 | 7 |
| 3. I ask myself this question, I don't seem to be able to manage the important tasks related to this work. | | | | 1 | 2 | 3 | 4 | 5 | 6 | 7 |
| 4. Because I derive much pleasure from learning new things. | | | | 1 | 2 | 3 | 4 | 5 | 6 | 7 |
| 5. Because it has become a fundamental part of who I am. | | | | 1 | 2 | 3 | 4 | 5 | 6 | 7 |
| 6. Because I want to succeed at this job, if not I would be very ashamed of myself. | | | | 1 | 2 | 3 | 4 | 5 | 6 | 7 |
| 7. Because I chose this type of work to attain my career goals. | | | | 1 | 2 | 3 | 4 | 5 | 6 | 7 |
| 8. For the satisfaction I experience from taking on interesting challenges | | | | 1 | 2 | 3 | 4 | 5 | 6 | 7 |
| 9. Because it allows me to earn money. | | | | 1 | 2 | 3 | 4 | 5 | 6 | 7 |
| 10. Because it is part of the way in which I have chosen to live my life. | | | | 1 | 2 | 3 | 4 | 5 | 6 | 7 |
| 11. Because I want to be very good at this work, otherwise I would be very disappointed. | | | | 1 | 2 | 3 | 4 | 5 | 6 | 7 |
| 12. I don't know why, we are provided with unrealistic working conditions. | | | | 1 | 2 | 3 | 4 | 5 | 6 | 7 |
| 13. Because I want to be a "winner" in life. | | | | 1 | 2 | 3 | 4 | 5 | 6 | 7 |
| 14. Because it is the type of work I have chosen to attain certain important objectives. | | | | 1 | 2 | 3 | 4 | 5 | 6 | 7 |
| 15. For the satisfaction I experience when I am successful at doing difficult tasks. | | | | 1 | 2 | 3 | 4 | 5 | 6 | 7 |
| 16. Because this type of work provides me with security. | | | | 1 | 2 | 3 | 4 | 5 | 6 | 7 |
| 17. I don't know, too much is expected of us. | | | | 1 | 2 | 3 | 4 | 5 | 6 | 7 |
| 18. Because this job is a part of my life. | | | | 1 | 2 | 3 | 4 | 5 | 6 | 7 |

Note. Intrinsic motivation = 4,8,15; integrated regulation = 5,10,18; identified regulation = 1,7,14; introjected regulation = 6,11,13; external regulation = 2,9,16; amotivation = 3,12,17.

Received August 31, 2007
 Revision received November 27, 2008
 Accepted December 1, 2008 ■