

Promoting enjoyment in girls' physical education: The impact of goals, beliefs, and self-determination

- **C.K. John Wang and W.C. Liu** Nanyang Technological University, Singapore

Abstract

This study examined the network of relationships between sport ability beliefs, achievement goals, self-determination and female students' enjoyment in school physical education (PE). Female secondary students ($n = 343$) from a single-sex secondary school in Singapore participated in the survey. They were assessed on sport ability beliefs, goal orientations, relative autonomy, perceived competence and enjoyment in PE. The findings established that incremental belief predicted task orientation. In addition, relative autonomy, task orientation and perceived competence had strong and direct impact on enjoyment. Overall, the present study offers some insightful thoughts for promoting enjoyment for girls in PE and physical activity.

Key-words: enjoyment • goal orientation • physical education • self-determination • sport ability beliefs

The benefits of regular physical activity are well established. Essentially, it has been documented that the benefits of regular physical activity in young people include areas such as cardiovascular fitness, psychological health, skeletal health, blood pressure, body composition and glucose, insulin and blood lipids levels (Biddle et al., 1998; Bouchard et al., 1994; Sallis, 1994). Despite the evidence supporting the benefits of physical activity participation, there is a decline in participation in physical activity in young people over their teenage years, and this decline is particularly obvious in girls (Pratt et al., 1999). Physical education (PE) in schools faces a major challenge in promoting girls' involvement in sport and physical activity, thus understanding motivation among girls in sport and PE contexts (Biddle, 2001; Duda and Hall, 2001) is a research priority (Sallis et al., 1992).

Many studies have shown that adolescent girls are less likely than their male counterparts to participate in physical activity (see Pratt et al., 1999; Vescio et al., 2005). As a result, they may put themselves at a greater risk of diseases, as well as miss out on the other benefits often claimed for participation in physical activity and sport. Furthermore, several recent studies have found evidence of lower participation

rates and higher drop out rates among girls than boys in school sport (e.g. De Knop et al., 1996; Schofield et al., 2002). Malaxos and Westwood (1997) established that the attrition rates for school sport remained very high, with almost 60 percent of females dropping out by the age of 15. Therefore, there is a need to increase our understanding of motivational determinants associated with physical activity in youth, particularly among female participants. The purpose of this study was to examine young females' motivation towards PE in schools using a combination of sport ability beliefs (Biddle et al., 2003a; Dweck, 1999; Wang and Biddle, 2001), achievement goal theory (Duda and Hall, 2001; Nicholls, 1989) and self-determination theory framework (SDT; Deci and Ryan, 1985; Ryan and Deci, 2000a, 2000b). Wang and Biddle (in press) have shown that integrating these three theories could provide a comprehensive explanation of young people's physical activity behaviour.

Sport ability beliefs

Research investigating the motivation of children and youth in physical activity has shown that the beliefs people hold about their ability could be one of the major influencing factors (Wang and Biddle, 2001). For example, girls may not like sport or exercise because they have a pre-existing belief that they are not 'cut out' to be sporty people. This is closely linked to two different ways in which people construe ability in achievement settings such as sport and PE classes.

According to Dweck and her colleagues (Dweck, 1999; Dweck and Leggett, 1988; Hong et al., 1995), some people see ability as an acquirable skill that can be increased through practice and effort. People with this incremental theory adopt a learning or task goal in skill development. They tend to view mistakes as part of learning and seek challenges that provide opportunities to increase their skills and competencies. In contrast, some people view ability as a capacity or fixed entity, and they cannot do very much to change that inherent aptitude. These people tend to adopt a performance or ego goal, and they strive to establish how much ability they have compared with others. In doing so, they prefer tasks that demonstrate their superiority and avoid tasks that show up their inadequacy. High effort exertion is seen as low ability, so easy tasks are preferred. When faced with obstacles, children with entity beliefs tend to show detrimental performance, and negative affect and cognitions. In comparison, those with incremental beliefs tend to show more adaptive motivational patterns, such as persistence, positive affect and effective problem-solving strategies (Dweck, 1986; Mueller and Dweck, 1998; Wang and Biddle, 2001).

In physical activity settings, Wang and Biddle (2001) found that high incremental belief was one of the key factors affecting intrinsic motivation towards PE. Entity or fixed belief, however, resulted in less adaptive motivational profiles. They also found that girls tended to be over-represented in the less adaptive motivational profiles as compared to boys. For example, the 'amotivated' cluster was 65.5 percent female and the 'poorly motivated' cluster was 66.3 percent female, while males were

over-represented in the 'highly motivated' cluster (66.8%). The less adaptive profiles were characterized by low task orientation, low incremental beliefs, high entity beliefs, low perceived competence, low RAI and high amotivation, while the highly motivated profile had the opposite pattern.

Typically, sport ability beliefs are assessed through the use of the Conception of the Nature of Athletic Ability Questionnaire (CNAAQ; Sarrazin et al., 1996). In a recent psychometric study, Biddle et al. (2003a) revised the original six first-order factor measurement model (Learning, Improvement, Specific, Gift, Stable and General) to four first-order factors (Learning, Improvement, Stable and Gift) and two higher-order factors (Incremental and Entity), using confirmatory factor analysis. That is, entity beliefs were underpinned by stable and gift beliefs, and incremental beliefs were underpinned by learning and improvement beliefs. They named it CNAAQ-version 2. In addition, they also found that entity and incremental beliefs predicted ego and task goal orientations, respectively. A recent study that examined the cross-cultural validity of the CNAAQ-2 between British and Singaporean samples found that the measurement tool had an invariant factor form and structure, as well as cross-cultural applicability (Wang et al., 2005). However, the relationship between the latent means seemed to differ between the two countries. As this was the only study involving an Asian sample, further examination of the CNAAQ-2 among Singaporean samples is warranted.

Achievement goal theory

The major theoretical tenet of achievement goal theory is that individuals strive to demonstrate ability and to avoid displaying incompetence in an achievement context. Thus, individuals are assumed to differentially endorse two different and subjective ways of defining success and failure, and judging their competence (Nicholls, 1989).

A task-oriented person tends to define success or judge his or her competence in a self-referenced manner, based on self-improvement or investing effort in task mastery. In contrast, an ego-involved person tends to define success in a normative fashion. Here, one aims to beat others or to outperform others with less effort. It is hypothesized that task-oriented individuals, regardless of their levels of perceived competence, exhibit positive or adaptive motivated behaviour. Similarly, ego-oriented individuals with high perceived competence should also have adaptive motivational patterns (Dweck, 1986; Nicholls, 1984, 1989). However, those with low perceived competence are likely to exhibit maladaptive motivational responses.

A recent systematic review on the correlates of achievement goal orientation was conducted by Biddle and his colleagues with a total of 98 studies and 110 independent samples ($N = 21,076$) (Biddle et al., 2003b). The results support the positive consequences of task orientation for motivation, while an ego orientation may not be ideal for the promotion of students' interest and motivation.

In Biddle et al.'s review (2003b), it was found that self-reported positive affect (such as enjoyment, satisfaction and pride) had a moderate-to-large positive association

with a task orientation but no relationship with an ego orientation. Furthermore, negative affect had a small negative association with a task orientation but no relationship with an ego orientation. However, the experimental study done by Spray et al. (2006) established that task and ego involvements affected the markers of intrinsic motivation. This shows that achievement goals are important variables to consider when examining motivational determinants.

According to the theories, sport ability beliefs are seen as antecedents of achievement goals (Biddle et al., 2003a; Dweck, 1999; Dweck and Leggett, 1988). Spray and his colleagues (Spray et al., 2006) provided support for the causal links between conceptions of sport ability and situational achievement goals. Using a field experimental design, they induced entity and incremental beliefs among 123 secondary school students in a sport task. Achievement goals were measured before and after failure. The results showed that the participants in the incremental group were more likely to adopt learning goals than the participants in the entity group, while the entity group was more likely to adopt comparison goals than the incremental group and the control group. Ability attributions for failure were stronger for the entity group than the incremental and control groups.

Self-determination theory

Motivation is not a simple dichotomous concept. In the self-determination theory proposed by Deci and Ryan (1985; Ryan and Deci, 2000a, 2000b), motivation is proposed to be a multidimensional concept. They presented a more differentiated view of motivation to explain the perceived forces that regulate human behaviour. On one side of the self-determination continuum, intrinsic motivation represents the motivation when one is doing something for its own sake and not for external rewards. On the other side of the continuum, extrinsic motivation is doing something as a means to an end. A state of amotivation also exists as one of the regulatory processes in self-determination theory. It refers to the relative lack of motivation, where an absence of contingency between actions and outcomes is perceived and reasons for continuing involvement cannot be found (Pelletier et al., 1995; Vallerand and Fortier, 1998). According to Deci and Ryan (1985), amotivation is labelled as the 'external boundary' of extrinsic motivation, and is seen as similar to feelings of helplessness.

The self-determination theory also posits that there are at least three main types of extrinsic regulatory processes: external regulation, introjected regulation and identified regulation. External regulation is characterized by behaviour that is controlled by external forces, such as rewards or punishments. Introjected regulation is behaviour controlled by internal pressure to act, such as avoidance of guilt and shame. Identified regulation involves acting out because behaviour is seen as personally important. It should be noted that Deci and Ryan (1985) also included integrated regulation as the most self-determined form of extrinsic motivation in the continuum. However, this regulation is developmentally less appropriate for children and adolescents (Vallerand and Fortier, 1998). In addition, all the instruments measuring

behavioural regulations in sport and exercise settings, including Perceived Locus of Causality (Goudas et al., 1994) which was adapted from Ryan and Connell's (1989) Self-Regulation Questionnaire; Sport Motivation Scale (Brière et al., 1995), Behavioural Regulation in Exercise Questionnaires (Mullan et al., 1997) did not include integrated regulation. Therefore, integrated regulation was excluded in this study.

Ryan and Connell (1989) suggested that these different types of motivation lie along a continuum of relative autonomy (self-determination continuum), ranging from least self-determined to highly self-determined, in the order of: external, introjected, identified and intrinsic. A Relative Autonomy Index (RAI) can be computed by weighting each subscale. Positive RAI indicates more self-determined regulation, whereas negative RAI indicates more controlling regulation. Koestner and Losier (2002) argued that, although the use of RAI may mask the relative contribution of each type of motivation, it does provide useful information about the 'big picture'.

Self-determination theory is closely linked to achievement goal theory (see Ntoumanis, 2001). Studies have shown that variations in achievement goals impact on different degrees of self-determination. For example, task orientation is linked to intrinsic motivation or more self-determined motivation, whereas ego orientation is associated with more controlling type of behavioural regulation (Deci and Ryan, 1987, 2000; Wang and Biddle, in press).

The present study

The three theories reviewed provide support that sport ability beliefs are antecedents of achievement goals, and achievement goals are linked to different types of behavioural regulation (e.g. Biddle et al., 1999; Sarrazin et al., 1996; Wang and Biddle, 2001; Wang et al., 2002). For example, incremental beliefs lead to task orientation, and entity beliefs underpin the adoption of ego orientation (Biddle et al., 2003a; Sarrazin et al., 1996; Spray et al., 2006; Wang et al., 2002). Task orientation is directly linked to intrinsic motivation, while ego orientation is linked to extrinsic motivation (Duda et al., 1995; Spray et al., 2006; Wang et al., 2002). However, not many studies have specifically examined girls' motivation towards PE, especially in the Asian context. There are concerns about girls' and young women's interest and participation in physical activity (Van Mechelen et al., 2000), and research that focuses on girls specifically may shed light on potential areas for intervention to enhance the motivation of adolescent girls for physical activity. Therefore, the purposes of the present study were: 1) to examine the factorial validity of the CNAAQ-2, and 2) to examine the network of relationships between sport ability beliefs, achievement goals, self-determination and girls' enjoyment in PE among a sample of female secondary school students in Singapore.

It was hypothesized that incremental beliefs predict task orientation, and entity beliefs predict ego orientation. Based on Biddle et al.'s (2003a) findings, we also hypothesized that entity beliefs negatively predict RAI and perceived competence. In line with the theories and results of past research, task orientation is thought to have

a direct positive impact on enjoyment. According to the operational definition of SDT, enjoyment can be used as the indicator of intrinsic motivation (Deci and Ryan, 1985). Furthermore, it was hypothesized that goal orientations directly affect perceived competence, which in turn influences enjoyment. These paths were predicted as perceived competence moderates the effects of achievement goals. Although the link between task orientation and perceived competence may not be in accordance with the theoretical predictions of Nicholls (1989), previous studies (e.g. Biddle et al., 1999; Lintunen et al., 1999) have consistently found the existence of the link between task orientation and perceived competence. This may be due to the way perceived competence is being measured. In the perceived competence subscale (PSP-PC; Fox and Corbin, 1989), one of the items is 'I feel that I am one of the best when it comes to joining in sport activities'. This is a norm-referenced competence, whereas another item is 'I am quite confident when it comes to taking part in sports activities', which measures self-referenced ability. Individuals can interpret competence in a self-referenced way, as well as normatively. Since this subscale is used in the current study, we hypothesized that both goals are linked to perceived competence. In addition, perceived competence and task orientation are positively related to self-determination (Ntoumanis, 2001; Standage et al., 2003), which in turn positively predicts enjoyment. Ego orientation, on the other hand, negatively predicts RAI (see Figure 1).

Methods

Participants and procedure

A total of 343 female students from a single-sex secondary school in Singapore participated in the survey. In Singapore, English is the first language in all schools. All the participants were attending Secondary Two levels (equivalent to Year 8 of United Kingdom). All the students ranged in age from 12 to 14 years ($M = 13.51$; $SD = .37$). Permission for the study was sought through the Principal and Head of PE department. Students were told that participation in the survey is voluntary and they were free to withdraw at any time. No pupil refused to take part. Questionnaires were administered in quiet classroom conditions with the presence of research assistants. When completing the questionnaire, participants were informed that there were no right or wrong answers. They were assured of the confidentiality of their responses, and were encouraged to ask questions if necessary.

Measures

Achievement goal orientations

Students' dispositional goal orientations were assessed using an established English version of the Task and Ego Orientation in Sport Questionnaire (TEOSQ; Duda and Nicholls, 1992). The stem for the 13 items was 'I feel most successful in physical education when . . .'. There were seven items measuring task orientation (e.g. 'I learn

a new skill and it makes me want to practise more') and six items measuring ego orientation (e.g. 'I can do better than my friends'). Answers were given on a five-point scale ranging from 1 (strongly disagree) to 5 (strongly agree).

Sport ability beliefs

The 'Conceptions of the Nature of Athletic Ability Questionnaire, Version 2' (CNAAQ-2; Biddle et al., 2003a; Wang and Biddle, 2001) was employed to examine females' incremental and entity beliefs. Incremental beliefs were assessed through two subscales, 'Learning' (3 items, e.g. 'to be successful in sport you need to learn techniques and skills, and practise them regularly') and 'Improvement' (3 items, e.g. 'how good you are at sport will always improve if you work at it'). Entity beliefs were also measured through two subscales, 'Stable' (3 items, e.g. 'it is difficult to change how good you are in sport') and 'Gift' (3 items, e.g. 'to be good in sport you need to be naturally gifted'). Responses were made on a five-point scale ranging from 1 (strongly disagree) to 5 (strongly agree).

Relative autonomy index (RAI)

The Perceived Locus of Causality (PLOC) scale developed by Goudas et al. (1994) was used to assess four types of regulatory styles in the PE context. The stem for all the items was 'I take part in PE . . .'. External regulation (e.g. 'because I'll get into trouble if I don't') and introjected regulation (e.g. 'because I'd feel bad about myself if I didn't') were assessed through four items each. Identified regulation (e.g. 'because I want to improve in PE') and intrinsic regulation (e.g. 'because PE is fun') were measured through three items each. Responses were also made on a five-point scale, similar to the CNAAQ-2. An overall relative autonomy index (RAI) was calculated by using the following procedure: external regulation $\times (-2)$ + introjected regulation $\times (-1)$ + identified regulation $\times (+1)$ + intrinsic regulation $\times (+2)$. This serves as an indicator of a person's motivational regulation, with positive scores indicating more autonomous regulation (i.e. self-determined) and negative scores more controlling regulation (RAI has a range of -12 to 12).

Perceived competence

The sport competence items from the children's version of the Physical Self-Perception Profile (PSPP-PC; Fox and Corbin, 1989) were administered. Example items included 'some people feel that they are good when it comes to playing sport in PE' and 'some people are quite confident when it comes to taking part in sports activities in PE'. Responses were given on a five-point scale ranging from 1 (strongly disagree) to 5 (strongly agree). The internal consistency of this subscale was .82.

Enjoyment

The enjoyment subscale of the Intrinsic Motivation Inventory (IMI; McAuley et al., 1989) was adapted to assess enjoyment (5 items, e.g. 'I usually enjoy playing sport in PE'). The items were measured on a five-point scale ranging from 1 (strongly disagree) to 5 (strongly agree). Cronbach's alpha for enjoyment was .90.

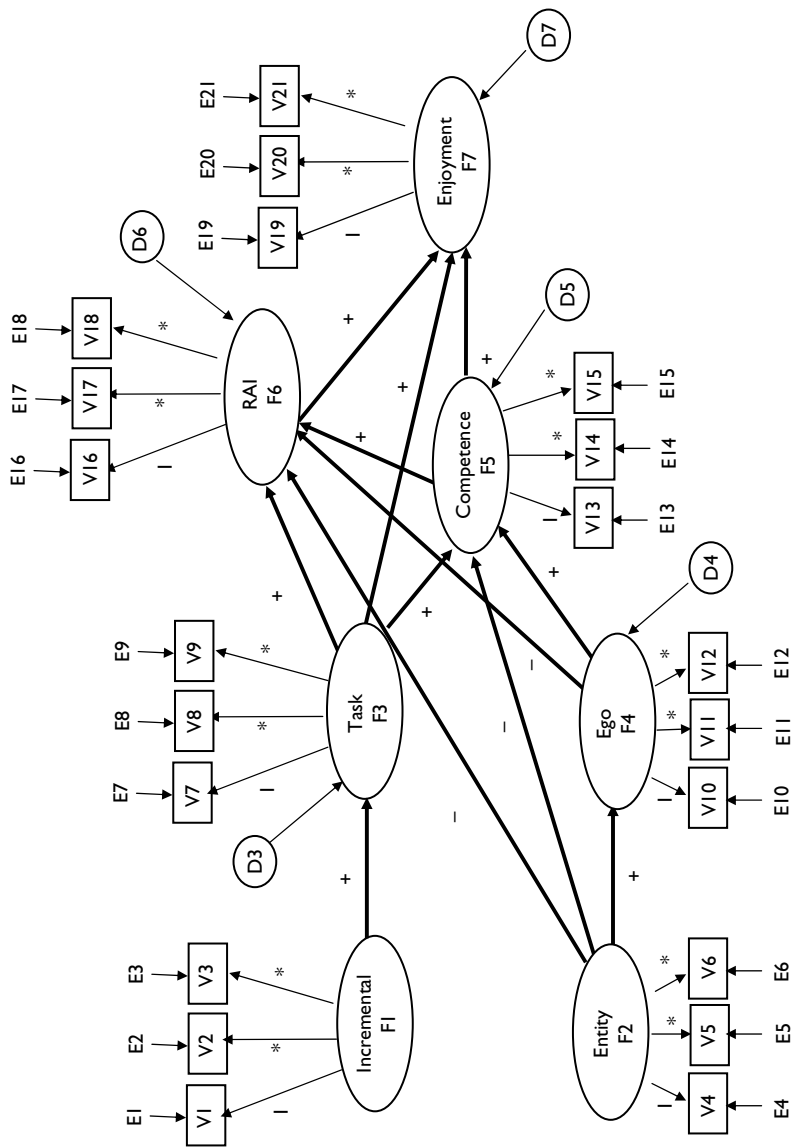

Figure 1 Proposed model of the relationship between sport ability beliefs, goal orientations, perceived competence, RAI and enjoyment in PE

Data analysis

To examine the psychometric properties of the measurement tools, we conducted confirmatory factor analyses (CFAs) on the TEOSQ, CNAAQ-2 and PLOC. The internal consistency coefficients of the scales were computed. Descriptive statistics and the Pearson product-moment correlations of the main variables were tabulated.

The network of relationships between the sport ability beliefs, goal orientations, RAI, perceived competence and enjoyment in PE was examined through EQS for Windows 6.1. We used a full latent variable model rather than a structural model. To reduce error correlations between multiple indicators and to facilitate interpretation, three items were randomly selected to represent a latent variable. For the three indicators of RAI, we used four weighted items to form each indicator, in accordance with previous latent variable models using these indices (e.g. Niemiec et al., 2006). A total of 21 indicators, representing seven latent factors, were used to represent the hypothesized structural model (see Figure 1).

In the initial analyses, there was no evidence of multivariate non-normality in the distribution (skewness and kurtosis $< \pm 1$, Mardia's coefficient = 89.46, normalized estimate = 25.58). Therefore, the Maximum Likelihood method was used as the estimation method.

In examining model fit of the CFA and the full latent model, a few fit indices would be reported. The most basic is chi-square, indicating the degree of discrepancy between the observed covariance matrix derived from the data and that predicted by the model. A small and non-significant chi-square indicates that the null hypothesis that the tested model fits the data cannot be rejected. However, this value is dependent on the sample size and is not sensitive to model complexity (Kelloway, 1998). Consequently, other indices of fit provided by EQS need to be considered when evaluating the adequacy of the models. These are: χ^2/df , Normed Fit Index (NFI); Comparative Fit Index (CFI); Goodness-of-Fit Index (GFI); Adjusted GFI (AGFI); Standardized Root Mean Squared Residual (SRMR); and Root Mean Squared Error of Approximation (RMSEA). The NFI is computed using the difference between the chi-square value for the proposed model and the null model. In the null model, the covariances in the covariance matrix for the latent variables are all assumed to be zero. CFI assesses the lack of fit based on the noncentrality measure of a target model compared to a null model. GFI and AGFI are indexes of absolute fit, that is, a measure of the proportion of variance and covariance that the proposed model accounted for. AGFI adjusts the GFI by taking into account the degree of freedom in the model (Hoyle and Panter, 1995). Hu and Bentler (1999) recommend values close to .95 as indication of good fit to the data.

The SRMR is the standardized difference between the implied and the observed covariance matrices. The RMSEA is also based on the analysis of residuals and compensates for the effects of model complexity. For these two indices of model fit, values close to .08 indicate a good fit to the data (Hu and Bentler, 1999). Recently, Marsh et al. (2004) caution about overgeneralization of Hu and Bentler's (1999) recommendations. They suggest that the indexes are more effective at identifying

differences in misspecification based on comparisons of nested models, rather than model fit. In assessing model fit, the traditional chi-square statistic may outperform these indexes.

In addition, model modifications can be investigated through the use of the Wald and Lagrange Multiplier Tests (LMT). The Wald test assesses whether any free parameters of a model can be restricted without substantial loss of information (Bentler, 1995). The LMT tests the opposite, that is, whether any parameters that were set to zero in the model are, in fact, not zero. It tests the effect of adding free parameters to a model (Bentler, 1995; Byrne, 1994). It is suggested that, although these post-hoc modifications are influenced by chance, the information can be useful in providing insight to variations of the hypothesized model. Changes are usually advised only when theoretically or logically justified.

Results

Psychometric properties of measurement tools

The results of the CFA on TEOSQ supported the factor structure ($\chi^2 = 208.53$, $df = 64$, $p < .001$, CFI = .935, GFI = .911, AGFI = .870, SRMR = .067 and RMSEA = .085, 90 percent CI of RMSEA = .072 to .096). Cronbach's alpha coefficients were .85 for task orientation and .92 for ego orientation.

A hierarchical confirmatory factor analysis with four first-order factors (Learning, Improvement, Stable and Gift) underpinning two second-order factors (Incremental and Entity) achieved a model fit of: $\chi^2 = 100.16$, $df = 51$, $p < .001$, CFI = .973, GFI = .954, AGFI = .930, SRMR = .050 and RMSEA = .053, 90 percent CI of RMSEA = .038 to .069. Cronbach's alpha coefficients showed that both incremental beliefs and entity beliefs were internally consistent (alphas were .87 for incremental and .83 for entity, calculated based on all the items representing the latent factor). The alpha coefficients for Learning, Improvement, Stable and Gift subscales were .79, .87, .74 and .81, respectively.

A confirmatory factor analysis was carried out using the maximum likelihood estimation procedure to examine the factor structure of the PLOC. The fit indices were satisfactory and supported the proposed four-factor structure: $\chi^2 = 191.91$, $df = 71$, $p < .001$, CFI = .935, GFI = .914, AGFI = .867, SRMR = .049, and RMSEA = .083, 90 percent CI of RMSEA = .070 to .096. Cronbach's alphas for external regulation, introjected regulation, identified regulation and intrinsic regulation were .87, .65, .73 and .86 respectively. It should be noted that the alpha for introjected regulation was just below the typically accepted level of 0.7. Due to the theoretical relevance of the construct, we retained this subscale in the present study. However, results pertaining to this construct should be interpreted with caution. The four types of behavioural regulations were correlated according to a simplex-like or ordered correlation structure (see Table 1), supporting the underlying continuum of autonomy. This provides justification for the use of RAI.

Table 1 Descriptive statistics and zero-order correlations between key variables of the overall sample

	Mean	SD	1	2	3	4	5	6	7	8	9	10
Incremental	3.92	.74	1.00									
Entity	2.79	.84	-.41**	1.00								
Task orientation	3.80	.69	.51**	-.19**	1.00							
Ego orientation	3.07	1.00	.16**	.05	.26**	1.00						
External regulation	2.34	1.07	-.27**	.33**	-.38**	-.05	1.00					
Introjected regulation	2.38	.76	-.09	.29**	.00	.19**	.47**	1.00				
Identified regulation	3.64	.80	.49**	-.21**	.59**	.13*	-.43**	.08	1.00			
Intrinsic regulation	3.79	.93	.45**	-.18**	.62**	.14**	-.58**	-.09	.69**	1.00		
RAI	3.75	4.38	.43**	-.32**	.56**	.07	-.90**	-.43**	.68**	.85**	1.00	
Competence	3.02	.67	.46**	-.32**	.45**	.29**	-.42**	.00	.51**	.53**	.52**	1.00
Enjoyment	3.68	.87	.44**	-.20**	.58**	.21**	-.59**	-.16**	.63**	.81**	.77**	.58**

* $p < 0.05$; ** $p < 0.01$.

Descriptive statistics

The means, standard deviations and correlations between the key variables of the overall sample are shown in Table 1. Overall, the female students had high task orientation, incremental beliefs and RAI, and moderately high levels of perceived competence and ego orientation. They also reported high level of enjoyment in PE classes. Task orientation was highly related to incremental beliefs, RAI, perceived competence and enjoyment, and moderately correlated with ego orientation. Ego orientation was found to be positively related to perceived competence and enjoyment but only moderately. Incremental beliefs were positively correlated with RAI, perceived competence and enjoyment. Entity beliefs, in contrast, were negatively related with incremental beliefs, RAI and perceived competence. RAI was positively related to perceived competence and enjoyment.

Structural equation modelling

The results of the structural equation modelling produced the following indices: $\chi^2 = 253.05$, $df = 176$, $\chi^2/df = 1.44$, $p < .001$, NFI = .921, CFI = .973, GFI = .930, AGFI = .906, SRMR = .056 and RMSEA = .039, 90 percent CI of RMSEA = .028 to .048. The standardized solutions and error variances of the hypothesized model are shown in Figure 2. Based on the adequacy of most of the fit indices, the proposed model was supported.

Discussion

The purposes of the present study were to examine the factor validity of the CNAAQ-2 and the network of relationships between sport ability beliefs, goal orientations, perceived competence, RAI and enjoyment among girls in PE. The results confirmed the hierarchical factor structure of the CNAAQ-2 and internal consistency among Singaporean sample. This is consistent with the previous study (Wang et al., 2005). In addition, the results in general showed that female secondary school students scored high in incremental beliefs, that is, they tended to endorse the beliefs that sport ability is changeable and can be improved through training. They also reported relatively high task orientation, and felt relatively autonomous to participate in PE classes. In the correlational analysis, incremental beliefs were positively associated with task orientation, RAI and perceived competence. These students also reported high enjoyment in their PE classes. Previous studies have shown that incremental beliefs, task orientation, RAI and perceived competence are strong predictors of enjoyment (Biddle et al., 2003a; Spray et al., 2006). Entity beliefs, however, are found to be negatively related with RAI and perceived competence. The results provided consistent relationships between sport ability beliefs, goals, RAI and enjoyment, which are in line with previous research that examined sport ability beliefs and feelings of self-determination (e.g. Kasimatis et al., 1996; Ntoumanis, 2001; Sun et al., 2001).

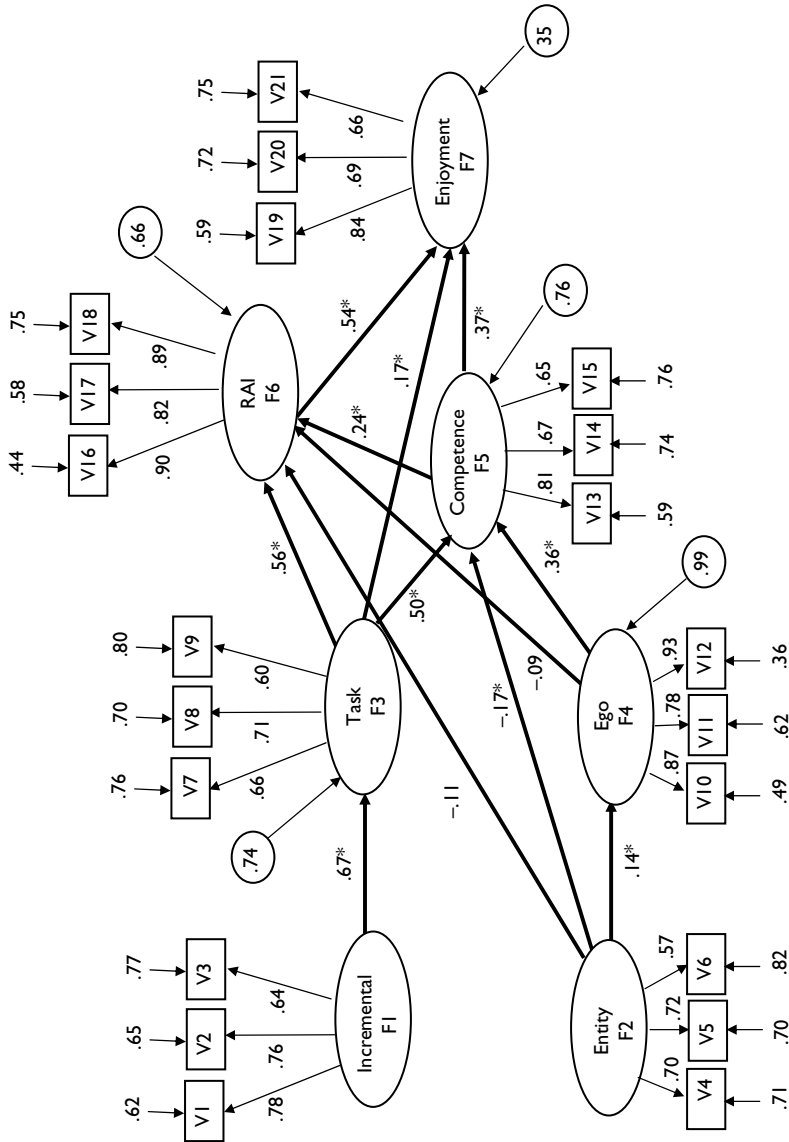

Note. *denotes $p < .05$.

Figure 2 Standardized solution for the proposed model

As indicated from the results of the structural equation modelling, task orientation was best predicted by an incremental belief, that is, a belief that sport ability can be improved as a result of periods of learning and practice. These findings are consistent with previous studies and the theoretical predictions (Dweck and Leggett, 1988; Sarrazin et al., 1996; Spray et al., 2006; Wang et al., 2007). In addition, task orientation and perceived competence also had strong and positive impact on RAI. The impact of entity beliefs and ego orientation on RAI were not strong. These findings support the theory in that task orientation promotes self-determination (e.g. Biddle and Wang, 2003; Deci and Ryan, 2000; Ryan, 1982). The unexpected result was the low path coefficient between entity beliefs and ego orientation ($\beta = .14, p < .05$), compared to the coefficient between incremental beliefs and task orientation, among this group of girls. In Biddle et al.'s (2003a) study with a British sample ($N = 2969$), the path coefficients were found to be $\beta = .40 (p < .05)$ for the high competent group and $\beta = .12 (p < .05)$ for the low competent group. This discrepancy in results may be a reflection of the differences in cognitive processes among females, compared to their male counterparts. It is recommended that future studies examine the underlying mechanism between entity beliefs and ego orientation among girls.

The findings of this study shed light on girls' motivation in physical activity in a PE context. The key psychological variables used in this study could explain a total of 88 percent of the total variance in enjoyment ($R^2 = 1 - (.35)^2$, see Figure 2). Overall, this supports the usefulness of integrating the three theories in increasing the predictive ability of the outcome variables.

The presence of the RAI in the proposed model added to our knowledge on the motivation of girls in PE. First, RAI had a direct impact on enjoyment. This finding supports self-determination theory in that intrinsic motivation will increase if the behavioural regulation is more autonomy or self-determined (Deci and Ryan, 1985, 1987). Second, the results showed that perceived competence could directly impact relative autonomy. This is in accordance with self-determination theory (Deci and Ryan, 1987; Ntoumanis, 2001). In the motivational sequence model proposed by Vallerand and Losier (1999), the effects of social factors on motivation are mediated by perceptions of competence, autonomy and relatedness. Therefore, high perceptions of competence will result in more self-determined behavioural regulation, thereby leading to positive cognitive, affective and behavioural consequences.

Overall, the present study offers some useful ideas for promoting enjoyment in PE and physical activity. First, it is important to promote incremental beliefs among female students in physical activity settings. Through focusing on the malleable aspects of sport ability, girls are more likely to adopt a mastery approach in taking part in sport or physical activity. In addition, incremental beliefs could lead to an increase in perceived competence. Research has shown that, although sport ability beliefs can be relatively stable personality traits, they can be highly dynamic as well (Dweck, 1999). In other words, individuals may have preference for one belief over another, but they also understand the opposing belief and sometimes endorse it, depending on situational factors. Thus, PE teachers should focus on increasing students' incremental beliefs and downplay the role of entity beliefs.

Second, PE must provide an enjoyable experience such that students do not feel that they are taking part in PE because of external rules or feeling of guilt. The results of the present study showed that, when students were more self-determined or intrinsically motivated, they enjoyed their PE experience more. These could be important in increasing their likelihood in physical activity participation. PE teachers should aim to promote more self-determined form of motivation and competence in their students during PE lessons. This, in turn, may foster intrinsic motivation to engage in physical activity outside PE lessons. In a recent study, Hagger and his colleagues (2005) proposed a transcontextual model and showed that perceived autonomy support in PE predicts autonomous motivation, intentions and behaviour in leisure-time physical activity context outside school.

In summary, this study provides support for the hierarchical measurement model of the CNAAQ-2 among the Singaporean sample and sheds light on the combined roles of sport ability beliefs, achievement goals and self-determination theory in the promotion of enjoyment among female secondary students in structured physical activity settings.

Finally, there are limitations in this study which need addressing in future research. First, this study measured the dispositional goal orientations of the students without taking into account the perceived environment (climate) or situational goal orientations. It would be of interest for researchers to examine these relationships in order to gain a more complete picture of the different factors affecting motivation. Second, this study did not look into the approach–avoidance dimension of achievement goals (Elliot, 1997; Elliot and Church, 1997; Elliot and Harackiewicz, 1996; Wang et al., 2007). There are studies that have argued that a full account of achievement goals in various settings requires attention to the approach–avoidance distinction in addition to the ego–task difference. Therefore, it would be of interest to investigate the differences between the different combination of goal profiles with sport ability beliefs and self-determination on intrinsic motivation. Third, this study used RAI as the composite score of the different regulatory styles. Koestner and Losier (2002) have argued that future research should focus on distinct regulatory styles to tease out the relative contribution of each type of motivation. Finally, the design of the study was cross-sectional and non-experimental. Future studies need to test the causality of the psychological variables through experimental design or longitudinal studies.

References

- Bentler, P.M. (1995) *EQS Structural Equations Program Manual*. Encino, CA: Multivariate Software.
- Biddle, S.J.H. (2001) 'Enhancing Motivation in Physical Education', in G.C. Roberts (ed.) *Advances in Motivation in Sport and Exercise*, pp. 101–27. Champaign, IL: Human Kinetics.
- Biddle, S.J.H. and Wang, C.K.J. (2003) 'Motivation and Self-Perception Profiles and Links with Physical Activity in Adolescent Girls', *Journal of Adolescence* 26: 687–701.
- Biddle, S., Sallis, J. and Cavill, N. (eds) (1998) *Young and Active? Young People and Health-Enhancing Physical Activity: Evidence and Implications*. London: Health Education Authority.
- Biddle, S., Soos, I. and Chatzisarantis, N. (1999) 'Predicting Physical Activity Using a Goal

- Perspective Approach: A Study of Hungarian Youth', *Scandinavian Journal of Medicine and Science in Sports* 9: 353–7.
- Biddle, S.J.H., Wang, C.K.J., Chatzisarantis, N.L.D. and Spray, C.M. (2003a) 'Motivation for Physical Activity in Young People: Entity and Incremental Beliefs Concerning Athletic Ability', *Journal of Sports Sciences* 21: 973–89.
- Biddle, S.J.H., Wang, C.K.J., Kavussanu, M. and Spray, C.S. (2003b) 'Correlates of Achievement Goal Orientations in Physical Activity: A Systematic Review of Research from 1990–2000', *European Journal of Sport Sciences* 3: 1–20.
- Bouchard, C., Shephard, R.J. and Stephens, T. (eds) (1994) *Physical Activity, Fitness and Health: International Proceedings and Consensus Statement*. Champaign, IL: Human Kinetics.
- Brière, N.M., Vallerand, R.J., Blais, M.R. and Pelletier, L.G. (1995) 'Développement et validation d'une mesure de motivation intrinsèque et d'amotivation en contexte sportif: l'Échelle de Motivation dans les Sports (EMS)', *International Journal of Sport Psychology* 26: 465–89.
- Byrne, B.M. (1994) *Structural Equation Modeling with EQS and EQS/Windows: Basic Concepts, Applications and Programming*. Newbury Park, CA: SAGE.
- De Knop, P., Engstrom, L.M., Skirstad, B. and Weiss, M.R. (1996) *Worldwide Trends in Youth Sport*. Champaign, IL: Human Kinetics.
- Deci, E.L. and Ryan, R.M. (1985) *Intrinsic Motivation and Self-Determination in Human Behavior*. New York: Plenum Press.
- Deci, E.L. and Ryan, R.M. (1987) 'The Support of Autonomy and the Control of Behavior', *Journal of Personality and Social Psychology* 53: 1024–37.
- Deci, E.L. and Ryan, R.M. (2000) 'The "What" and "Why" of Goal Pursuits: Human Needs and the Self-Determination of Behavior', *Psychological Inquiry* 11: 227–68.
- Duda, J.L. and Hall, H. (2001) 'Achievement Goal Theory in Sport: Recent Extensions and Future Directions', in R.N. Singer, H.A. Hausenblas and C.M. Janelle (eds) *Handbook of Sport Psychology*, pp. 417–43. New York: Wiley.
- Duda, J.L. and Nicholls, J.G. (1992) 'Dimensions of Achievement Motivation in Schoolwork and Sport', *Journal of Educational Psychology* 84: 290–99.
- Duda, J.L., Chi, L., Newton, M., Walling, M. and Catley, D. (1995) 'Task and ego orientation and intrinsic motivation in sport', *International Journal of Sport Psychology* 26: 40–63.
- Dweck, C.S. (1986) 'Motivational Processes Affecting Learning', *American Psychologist* 41: 1040–8.
- Dweck, C.S. (1999) *Self-Theories: Their Role in Motivation, Personality, and Development*. Philadelphia: Psychology Press.
- Dweck, C.S. and Leggett, E. (1988) 'A Social-Cognitive Approach to Motivation and Personality', *Psychological Review* 95: 256–73.
- Elliot, A.J. (1997) 'Integrating the "Classic" and "Contemporary" Approaches to Achievement Motivation: A Hierarchical Model of Approach and Avoidance Achievement Motivation', in M.L. Maehr and P.R. Pintrich (eds) *Advances in Motivation and Achievement*, vol. 10, pp. 143–79. Greenwich, CT: JAI Press.
- Elliot, A.J. and Church, M. (1997) 'A Hierarchical Model of Approach and Avoidance Achievement Motivation', *Journal of Personality and Social Psychology* 72: 218–32.
- Elliot, A.J. and Harackiewicz, J.M. (1996) 'Approach and Avoidance Achievement Goals and Intrinsic Motivation: A Mediation Analysis', *Journal of Personality and Social Psychology* 70: 461–75.
- Fox, K.R. and Corbin, B.C. (1989) 'The Physical Self-Perception Profile: Development and Preliminary Validation', *Journal of Sport and Exercise Psychology* 11: 408–30.
- Goudas, M., Biddle, S. and Fox, K. (1994) 'Perceived Locus of Causality, Goal Orientations and Perceived Competence in School Physical Education Classes', *British Journal of Educational Psychology* 64: 453–63.

- Hagger, M.S., Chatzisarantis, N., Barkoukis, V., Wang, C.K.J. and Baranowski, J. (2005) 'Perceived Autonomy Support in Physical Education Influences Autonomous Motives and Intentions toward Physical Activity in a Leisure-Time Context: A Cross-Cultural Evaluation of the Trans-Contextual Model', *Journal of Educational Psychology* 97: 376–90.
- Hong, Y., Chiu, C. and Dweck, C.S. (1995) 'Implicit Theories of Intelligence: Reconsidering the Role of Confidence in Achievement Motivation', in M.H. Kernis (ed.) *Efficacy, Agency, and Self-Esteem*, pp. 197–216. New York: Plenum Press.
- Hoyle, R.H. and Panter, A.T. (1995) 'Writing about Structural Equation Models', in R.H. Hoyle (ed.) *Structural Equation Modeling: Concepts, Issues, and Applications*, pp. 158–76. Newbury Park, CA: SAGE.
- Hu, L. and Bentler, P.M. (1999) 'Cutoff Criteria for Fit Indexes in Covariance Structure Analysis: Conventional Criteria Versus New Alternatives', *Structural Equation Modeling* 6: 1–55.
- Kasimatis, M., Miller, M. and Marcussen, L. (1996) 'The Effects of Implicit Theories on Exercise Motivation', *Journal of Research in Personality* 30: 510–16.
- Kelloway, E.K. (1998) *Using LISREL for Structural Equation Modeling: A Researcher's Guide*. Newbury Park, CA: SAGE.
- Koestner, R. and Losier, G.F. (2002) 'Distinguishing Three Ways of Being Internally Motivated: A Closer Look at Introjection, Identification, and Intrinsic Motivation', in E.L. Deci and R.M. Ryan (eds) *Handbook of Self-Determination Research*, pp. 101–21. Rochester, NY: University of Rochester Press.
- Lintunen, T., Valkonen, A., Leskinen, E. and Biddle, S.J.H. (1999) 'Predicting Physical Activity Intentions Using a Goal Perspectives Approach: A Study of Finnish Youth', *Scandinavian Journal of Medicine and Science in Sports* 9: 344–52.
- McAuley, E., Duncan, T.E. and Tammen, V.V. (1989) 'Psychometric Properties of the Intrinsic Motivation Inventory in a Competitive Sport Setting: A Confirmatory Factor Analysis', *Research Quarterly for Exercise and Sport* 60: 48–58.
- Malaxos, S. and Westwood, N. (1997) *Teenage Girls' Perceptions on Participation of Sport: Girls Want to Play Sport . . . But Why Don't They?* Perth: Womensport West.
- Marsh, H.W., Hau, K. and Wen, Z. (2004) 'In Search of Golden Rules: Comment on Hypothesis-Testing Approaches to Setting Cutoff Values for Fit Indexes and Dangers in Overgeneralizing Hu and Bentler's (1999) Findings', *Structural Equation Modeling* 11: 320–41.
- Mueller, C.M. and Dweck, C.S. (1998) 'Praise for Intelligence Can Undermine Children's Motivation and Performance', *Journal of Personality and Social Psychology* 75(1): 33–52.
- Mullan, E., Markland, D. and Ingledew, D.K. (1997) 'A Graded Conceptualisation of Self-Determination in the Regulation of Exercise Behaviour: Development of a Measure Using Confirmatory Factor Analytic Procedures', *Personal Individual Differences* 23: 745–52.
- Nicholls, J.G. (1984) 'Conceptions of Ability and Achievement Motivation', in *Research on Motivation in Education: Student Motivation*, vol. 1, pp. 39–73. New York: Academic Press.
- Nicholls, J.G. (1989) *The Competitive Ethos and Democratic Education*. Cambridge, MA: Harvard University Press.
- Niemiec, C.P., Lynch, M.F., Vansteenkiste, M., Bernstein, J., Deci, E.L. and Ryan, R.M. (2006) 'The Antecedents and Consequences of Autonomous Self-Regulation for College: A Self-Determination Theory Perspective on Socialization', *Journal of Adolescence* 29: 761–75.
- Ntoumanis, N. (2001) 'Empirical Links between Achievement Goal Theory and Self-Determination in Sport', *Journal of Sports Sciences* 19: 397–409.
- Pelletier, L.G., Fortier, M.S., Vallerand, R.J., Tuson, K.M., Brière, N.M. and Blais, M.R. (1995) 'Towards a New Measure of Intrinsic Motivation, Extrinsic Motivation, and Amotivation in Sports: The Sport Motivation Scale (SMS)', *Journal of Sport and Exercise Psychology* 17: 35–53.
- Pratt, M., Macera, C.A. and Blanton, C. (1999) 'Levels of Physical Activity and Inactivity in

- Children and Adults in the United States: Current Evidence and Research Issues', *Medicine and Science in Sports and Exercise* 31(11, suppl.): S526–S533.
- Ryan, R. (1982) 'Control and Information in Intrapersonal Sphere: An Extension of Cognitive Evaluation Theory', *Journal of Personality and Social Psychology* 43: 450–61.
- Ryan, R.M. and Connell, J.P. (1989) 'Perceived Locus of Causality and Internalization: Examining Reasons for Acting in Two Domains', *Journal of Personality and Social Psychology* 57: 749–61.
- Ryan, R.M. and Deci, E.L. (2000a) 'Intrinsic and Extrinsic Motivations: Classic Definitions and New Directions', *Contemporary Educational Psychology* 25: 54–67.
- Ryan, R.M. and Deci, E.L. (2000b) 'Self-Determination Theory and the Facilitation of Intrinsic Motivation, Social Development and Well-Being', *American Psychologist* 55(1): 68–78.
- Sallis, J.F. (1994) 'Influences on Physical Activity of Children, Adolescents, and Adults on Determinants of Active Living', *President's Council for Physical Fitness and Sports Physical Activity and Fitness Research Digest*, series 1: 1–8.
- Sallis, J.F., Simons-Morton, B.G., Stone, E.J., Corbin, C.B., Epstein, L.H., Faucette, N., et al. (1992) 'Determinants of Physical Activity and Interventions in Youth', *Medicine and Science in Sports and Exercise* 24(6, suppl.): S248–S257.
- Sarrazin, P., Biddle, S.J.H., Famose, J.P., Cury, F., Fox, K. and Durand, M. (1996) 'Goal Orientations and Conceptions of the Nature of Sport Ability in Children: A Social Cognitive Approach', *British Journal of Social Psychology* 35: 399–414.
- Schofield, L., Mummery, K., Schofield, G. and Walmsely, H. (2002) 'Adolescent Girls and Inactivity: Insights from the Central Queensland Adolescent Physical Activity and Nutrition Study', *ACHPER Healthy Lifestyles Journal* 49: 17–22.
- Spray, C.M., Wang, C.K.J., Biddle, S.J.H., Chatzisarantis, N.L.D. and Warburton, V.E. (2006) 'An Experimental Test of Self-Theories of Ability in Youth Sport', *Psychology of Sport and Exercise* 7: 255–67.
- Standage, M., Duda, J.L. and Ntoumanis, N. (2003) 'Predicting Motivational Regulations in Physical Education: The Interplay Between Dispositional Goal Orientations, Motivational Climate and Perceived Competence', *Journal of Sports Sciences* 21: 631–47.
- Sun, Y., Wang, C.K.J. and Biddle, S.J.H. (2001) 'Goal Orientation and Self-Determination Theories in Youth Physical Activity: Age and Gender Differences', *Journal of Tianjin Institute of Physical Education* 16(3): 10–14.
- Vallerand, R.J. and Fortier, M.S. (1998) 'Measures of Intrinsic and Extrinsic Motivation in Sport and Physical Activity: A Review and Critique', in J.L. Duda (ed.) *Advances in Sport and Exercise Psychology Measurement*, pp. 81–101. Morgantown, WV: Fitness Information Technology.
- Vallerand, R.J. and Losier, G.F. (1999) 'An Integrative Analysis of Intrinsic and Extrinsic Motivation in Sport', *Journal of Applied Sport Psychology* 11: 142–69.
- Van Mechelen, W., Twisk, J.W., Post, G.B., Snel, J. and Kemper, H.C. (2000) 'Physical Activity of Young People: The Amsterdam Longitudinal Growth and Health Study', *Medicine and Science in Sports and Exercise* 32: 1610–16.
- Vescio, J., Wilde, K. and Crosswhite, J.J. (2005) 'Profiling Sport Role Models to Enhance Initiatives for Adolescent Girls in Physical Education and Sport', *European Physical Education Review* 11: 153–70.
- Wang, C.K.J. and Biddle, S.J.H. (2001) 'Young People's Motivational Profiles in Physical Activity: A Cluster Analysis', *Journal of Sport and Exercise Psychology* 23: 1–22.
- Wang, C.K.J. and Biddle, S.J.H. (in press) 'Understanding Young People's Motivation towards Exercise: An Integration of Sport Ability Beliefs, Achievement Goals Theory, and Self-Determination Theory', in M. Hagger and N.L.D. Chatzisarantis (eds) *Self-Determination Theory in Exercise and Sport*. Champaign, IL: Human Kinetics.

- Wang, C.K.J., Biddle, S.J.H. and Elliot, A. (2007) 'The 2 x 2 Achievement Goal Framework in a Physical Education Context', *Psychology of Sport and Exercise* 8: 147–68.
- Wang, C.K.J., Chatzisarantis, N.L.D., Spray, C.M. and Biddle, S.J.H. (2002) 'Achievement Goal Profiles in School Physical Education: Differences in Self-Determination, Sport Ability Beliefs, and Physical Activity', *British Journal of Educational Psychology* 72: 433–45.
- Wang, C.K.J., Liu, W.C., Biddle, S.J.H. and Spray, C.M. (2005) 'Cross-Cultural Validation of the Conceptions of the Nature of Athletic Ability Questionnaire Version 2', *Personality and Individual Differences* 38: 1245–56.

Résumé

Incitation au plaisir de pratiquer en éducation physique pour les filles: impact des objectifs, des convictions et de l'auto-détermination

Cette étude a porté sur le réseau de relations établi entre les convictions de capacité sportive, les objectifs de réussite, l'auto-détermination et le plaisir à pratiquer des lycéennes en éducation physique scolaire. Des élèves ($n = 343$) d'un lycée pour filles de Singapour ont participé à cette étude. Elles ont été évaluées sur leurs convictions quant à leur capacité sportive, les orientations de leurs objectifs, leur relative autonomie, la perception de leur compétence et leur plaisir de pratiquer l'éducation physique. Il a été établi que le niveau de conviction était prédictif de l'orientation de leurs objectifs. De plus, l'autonomie relative, l'orientation de la tâche et la compétence perçue ont également un impact fort et direct sur leur plaisir à pratiquer. En définitive, cette étude offre une réflexion intéressante sur l'incitation au plaisir dans la pratique de l'éducation physique et de l'activité physique chez les filles.

Resumen

Promoción de la diversión en las clases de educación física femenina: El impacto de los objetivos, las creencias y la auto confianza

El estudio examina el taller de relaciones entre habilidades deportivas, creencias, objetivos planteados, auto confianza y divertimento de las estudiantes femeninas en la educación física escolar. Participaron en este taller ($n = 343$) chicas, estudiantes de un colegio femenino de Singapur. Fueron evaluadas sobre habilidades deportivas, creencias, orientación de los objetivos, autonomía personal, auto confianza y disfrute o diversión en las clases de educación física. Los resultados establecieron un incremento significativo de que la consecución de objetivos, que mejoraba el nivel de creencias y la relación entre la autonomía personal relativa, la competencia personal percibida tenía una fuerte influencia y un impacto directo sobre el grado de satisfacción personal en el as clases de educación física. Además, este estudio, aporta algunas ideas significativas sobre la promoción de la satisfacción y el divertimento personal de las alumnas en clases de educación física y actividades físicas.

Zusammenfassung

Förderung von Spaß im Schulsport für Mädchen: Der Einfluss von Zielen, Zutrauen und Selbstbestimmung

Diese Studie untersuchte den Zusammenhang von sportlichen Fähigkeitsselbstkonzepten, Leistungszielen, Selbstbestimmung und Spaß bei Schülerinnen im Schulsport. Teilnehmerinnen der Studie waren Schülerinnen einer Sekundarstufe ($n = 343$) einer Mädchenschule in Singapur. Sie wurden untersucht mit Blick auf ihr sportliches Fähigkeitsselbstkonzept, Zielorientierung, relative Autonomie, wahrgenommene Kompetenz und Spaß im Schulsport. Die Ergebnisse indizieren einen Zusammenhang zwischen einem schrittweisen Zuwachs an Selbstvertrauen und einer antizipierbaren Aufgabenorientierung. Außerdem haben relative Autonomie, Aufgabenorientierung und wahrgenommene Kompetenz einen starken und direkten Einfluss auf den Spaß-Faktor. Insgesamt bietet die Studie einige aufschlussreiche Denkansätze zur Förderung von Freude der Mädchen am Sportunterricht und an sportlicher Aktivität.

Address for correspondence: Dr C.K. John Wang, PhD, Physical Education and Sports Science, National Institute of Education, Blk 5 #03–20, 1 Nanyang Walk, Singapore 637616. [email: john.wang@nie.edu.sg]
